

Parts list for Revision H

Part reference numbers may be used to help locate the part per the following table:

Reference Designator	Location
100 to 149	10MHz oven oscillator (front vertical) PCB
150 to 199	Crystal heater PCB (front vertical)
200 to 299	Analog servos and amplifiers (top) PCB
300 to 399	Microcontroller (left-side, vertical) PCB
400 to 499	Frequency synthesizer (right side, vert) PCB
500 to 599	P/S and 1PPS circuits (bottom) PCB
600 to 699	Cell heater PCB (rear vertical)
700 to 799	Inside the resonance cell
800 to 899	Lamp heater PCB (center vertical)
900 to 999	Inside lamp enclosure

<u>REF.</u>	<u>SRS PART</u>	<u>VALUE</u>	<u>DESCRIPTION</u>
C 100	5-00318-569	2.2U/T35	Cap. Tantalum, SMT (all case sizes)
C 101	5-00299-568	.1U	Cap. Ceramic 50V SMT (1206) +/-10% X7R
C 102	5-00370-552	39P	Capacitor, Chip (SMT1206), 50V, 5%, NPO
C 103	5-00375-552	100P	Capacitor, Chip (SMT1206), 50V, 5%, NPO
C 106	5-00298-568	.01U	Cap. Ceramic 50V SMT (1206) +/-10% X7R
C 107	5-00298-568	.01U	Cap. Ceramic 50V SMT (1206) +/-10% X7R
C 108	5-00298-568	.01U	Cap. Ceramic 50V SMT (1206) +/-10% X7R
C 109	4-01146-462	2.00K	Thin Film, 1%, 50 ppm, MELF Resistor
C 110	5-00299-568	.1U	Cap. Ceramic 50V SMT (1206) +/-10% X7R
C 111	5-00387-552	1000P	Capacitor, Chip (SMT1206), 50V, 5%, NPO
C 112	5-00361-552	6.8P	Capacitor, Chip (SMT1206), 50V, 5%, NPO
C 113	5-00375-552	100P	Capacitor, Chip (SMT1206), 50V, 5%, NPO
C 114	5-00299-568	.1U	Cap. Ceramic 50V SMT (1206) +/-10% X7R
C 115	5-00472-569	4.7U/T35	Cap. Tantalum, SMT (all case sizes)
C 116	5-00472-569	4.7U/T35	Cap. Tantalum, SMT (all case sizes)
C 151	5-00299-568	.1U	Cap. Ceramic 50V SMT (1206) +/-10% X7R
C 152	5-00299-568	.1U	Cap. Ceramic 50V SMT (1206) +/-10% X7R
C 200	5-00387-552	1000P	Capacitor, Chip (SMT1206), 50V, 5%, NPO
C 201	5-00466-572	.1U	SMT Film Capacitors, 50V, 5%, All Sizes
C 202	5-00299-568	.1U	Cap. Ceramic 50V SMT (1206) +/-10% X7R
C 203	5-00387-552	1000P	Capacitor, Chip (SMT1206), 50V, 5%, NPO
C 204	5-00466-572	.1U	SMT Film Capacitors, 50V, 5%, All Sizes
C 205	5-00299-568	.1U	Cap. Ceramic 50V SMT (1206) +/-10% X7R
C 206	5-00387-552	1000P	Capacitor, Chip (SMT1206), 50V, 5%, NPO
C 207	5-00466-572	.1U	SMT Film Capacitors, 50V, 5%, All Sizes
C 208	5-00299-568	.1U	Cap. Ceramic 50V SMT (1206) +/-10% X7R
C 210	5-00387-552	1000P	Capacitor, Chip (SMT1206), 50V, 5%, NPO

<u>REF.</u>	<u>SRS PART</u>	<u>VALUE</u>	<u>DESCRIPTION</u>
C 212	5-00299-568	.1U	Cap, Ceramic 50V SMT (1206) +/-10% X7R
C 216	5-00387-552	1000P	Capacitor, Chip (SMT1206), 50V, 5%, NPO
C 217	5-00466-572	.1U	SMT Film Capacitors, 50V, 5%, All Sizes
C 218	5-00299-568	.1U	Cap, Ceramic 50V SMT (1206) +/-10% X7R
C 219	5-00375-552	100P	Capacitor, Chip (SMT1206), 50V, 5%, NPO
C 220	5-00466-572	.1U	SMT Film Capacitors, 50V, 5%, All Sizes
C 221	5-00454-572	.01U	SMT Film Capacitors, 50V, 5%, All Sizes
C 222	5-00454-572	.01U	SMT Film Capacitors, 50V, 5%, All Sizes
C 223	5-00299-568	.1U	Cap, Ceramic 50V SMT (1206) +/-10% X7R
C 224	5-00299-568	.1U	Cap, Ceramic 50V SMT (1206) +/-10% X7R
C 226	5-00466-572	.1U	SMT Film Capacitors, 50V, 5%, All Sizes
C 227	5-00466-572	.1U	SMT Film Capacitors, 50V, 5%, All Sizes
C 228	5-00299-568	.1U	Cap, Ceramic 50V SMT (1206) +/-10% X7R
C 229	5-00299-568	.1U	Cap, Ceramic 50V SMT (1206) +/-10% X7R
C 230	5-00299-568	.1U	Cap, Ceramic 50V SMT (1206) +/-10% X7R
C 301	5-00299-568	.1U	Cap, Ceramic 50V SMT (1206) +/-10% X7R
C 302	5-00299-568	.1U	Cap, Ceramic 50V SMT (1206) +/-10% X7R
C 304	5-00299-568	.1U	Cap, Ceramic 50V SMT (1206) +/-10% X7R
C 306	5-00299-568	.1U	Cap, Ceramic 50V SMT (1206) +/-10% X7R
C 308	5-00298-568	.01U	Cap, Ceramic 50V SMT (1206) +/-10% X7R
C 309	5-00375-552	100P	Capacitor, Chip (SMT1206), 50V, 5%, NPO
C 310	5-00375-552	100P	Capacitor, Chip (SMT1206), 50V, 5%, NPO
C 311	5-00472-569	4.7U/T35	Cap, Tantalum, SMT (all case sizes)
C 400	5-00299-568	.1U	Cap, Ceramic 50V SMT (1206) +/-10% X7R
C 401	5-00299-568	.1U	Cap, Ceramic 50V SMT (1206) +/-10% X7R
C 402	5-00387-552	1000P	Capacitor, Chip (SMT1206), 50V, 5%, NPO
C 403	5-00387-552	1000P	Capacitor, Chip (SMT1206), 50V, 5%, NPO
C 404	5-00299-568	.1U	Cap, Ceramic 50V SMT (1206) +/-10% X7R
C 405	5-00299-568	.1U	Cap, Ceramic 50V SMT (1206) +/-10% X7R
C 406	5-00387-552	1000P	Capacitor, Chip (SMT1206), 50V, 5%, NPO
C 407	5-00466-572	.1U	SMT Film Capacitors, 50V, 5%, All Sizes
C 408	5-00298-568	.01U	Cap, Ceramic 50V SMT (1206) +/-10% X7R
C 409	5-00466-572	.1U	SMT Film Capacitors, 50V, 5%, All Sizes
C 410	5-00462-572	.047U	SMT Film Capacitors, 50V, 5%, All Sizes
C 411	5-00299-568	.1U	Cap, Ceramic 50V SMT (1206) +/-10% X7R
C 413	5-00299-568	.1U	Cap, Ceramic 50V SMT (1206) +/-10% X7R
C 414	5-00373-552	68P	Capacitor, Chip (SMT1206), 50V, 5%, NPO
C 415	5-00375-552	100P	Capacitor, Chip (SMT1206), 50V, 5%, NPO
C 416	5-00387-552	1000P	Capacitor, Chip (SMT1206), 50V, 5%, NPO
C 417	5-00387-552	1000P	Capacitor, Chip (SMT1206), 50V, 5%, NPO
C 418	5-00375-552	100P	Capacitor, Chip (SMT1206), 50V, 5%, NPO
C 419	5-00456-572	.015U	SMT Film Capacitors, 50V, 5%, All Sizes
C 420	5-00456-572	.015U	SMT Film Capacitors, 50V, 5%, All Sizes
C 421	5-00299-568	.1U	Cap, Ceramic 50V SMT (1206) +/-10% X7R
C 422	5-00298-568	.01U	Cap, Ceramic 50V SMT (1206) +/-10% X7R
C 423	5-00299-568	.1U	Cap, Ceramic 50V SMT (1206) +/-10% X7R
C 424	5-00387-552	1000P	Capacitor, Chip (SMT1206), 50V, 5%, NPO
C 425	5-00387-552	1000P	Capacitor, Chip (SMT1206), 50V, 5%, NPO
C 426	5-00299-568	.1U	Cap, Ceramic 50V SMT (1206) +/-10% X7R
C 427	5-00375-552	100P	Capacitor, Chip (SMT1206), 50V, 5%, NPO

<u>REF.</u>	<u>SRS PART</u>	<u>VALUE</u>	<u>DESCRIPTION</u>
C 428	5-00387-552	1000P	Capacitor, Chip (SMT1206), 50V, 5%, NPO
C 429	5-00298-568	.01U	Cap. Ceramic 50V SMT (1206) +/-10% X7R
C 430	5-00359-552	4.7P	Capacitor, Chip (SMT1206), 50V, 5%, NPO
C 431	5-00356-552	2.7P	Capacitor, Chip (SMT1206), 50V, 5%, NPO
C 432	5-00299-568	.1U	Cap. Ceramic 50V SMT (1206) +/-10% X7R
C 433	5-00364-552	12P	Capacitor, Chip (SMT1206), 50V, 5%, NPO
C 434	5-00366-552	18P	Capacitor, Chip (SMT1206), 50V, 5%, NPO
C 436	5-00299-568	.1U	Cap. Ceramic 50V SMT (1206) +/-10% X7R
C 437	5-00299-568	.1U	Cap. Ceramic 50V SMT (1206) +/-10% X7R
C 438	5-00466-572	.1U	SMT Film Capacitors, 50V, 5%, All Sizes
C 439	5-00298-568	.01U	Cap. Ceramic 50V SMT (1206) +/-10% X7R
C 440	5-00466-572	.1U	SMT Film Capacitors, 50V, 5%, All Sizes
C 500	5-00318-569	2.2U/T35	Cap. Tantalum, SMT (all case sizes)
C 502	5-00318-569	2.2U/T35	Cap. Tantalum, SMT (all case sizes)
C 504	5-00387-552	1000P	Capacitor, Chip (SMT1206), 50V, 5%, NPO
C 506	5-00318-569	2.2U/T35	Cap. Tantalum, SMT (all case sizes)
C 507	5-00318-569	2.2U/T35	Cap. Tantalum, SMT (all case sizes)
C 508	5-00318-569	2.2U/T35	Cap. Tantalum, SMT (all case sizes)
C 509	5-00387-552	1000P	Capacitor, Chip (SMT1206), 50V, 5%, NPO
C 510	5-00356-552	2.7P	Capacitor, Chip (SMT1206), 50V, 5%, NPO
C 511	5-00387-552	1000P	Capacitor, Chip (SMT1206), 50V, 5%, NPO
C 512	5-00299-568	.1U	Cap. Ceramic 50V SMT (1206) +/-10% X7R
C 513	5-00376-552	120P	Capacitor, Chip (SMT1206), 50V, 5%, NPO
C 514	5-00299-568	.1U	Cap. Ceramic 50V SMT (1206) +/-10% X7R
C 515	5-00387-552	1000P	Capacitor, Chip (SMT1206), 50V, 5%, NPO
C 516	5-00299-568	.1U	Cap. Ceramic 50V SMT (1206) +/-10% X7R
C 517	5-00299-568	.1U	Cap. Ceramic 50V SMT (1206) +/-10% X7R
C 518	5-00299-568	.1U	Cap. Ceramic 50V SMT (1206) +/-10% X7R
C 519	5-00299-568	.1U	Cap. Ceramic 50V SMT (1206) +/-10% X7R
C 520	5-00299-568	.1U	Cap. Ceramic 50V SMT (1206) +/-10% X7R
C 521	5-00299-568	.1U	Cap. Ceramic 50V SMT (1206) +/-10% X7R
C 600	5-00299-568	.1U	Cap. Ceramic 50V SMT (1206) +/-10% X7R
C 601	5-00299-568	.1U	Cap. Ceramic 50V SMT (1206) +/-10% X7R
C 602	5-00299-568	.1U	Cap. Ceramic 50V SMT (1206) +/-10% X7R
C 700	5-00480-574	5.6P 500V	SMT, High Voltage Porcelain Cap.
C 800	5-00299-568	.1U	Cap. Ceramic 50V SMT (1206) +/-10% X7R
C 801	5-00299-568	.1U	Cap. Ceramic 50V SMT (1206) +/-10% X7R
C 802	5-00387-552	1000P	Capacitor, Chip (SMT1206), 50V, 5%, NPO
C 803	5-00387-552	1000P	Capacitor, Chip (SMT1206), 50V, 5%, NPO
C 804	5-00299-568	.1U	Cap. Ceramic 50V SMT (1206) +/-10% X7R
C 805	5-00387-552	1000P	Capacitor, Chip (SMT1206), 50V, 5%, NPO
C 900	5-00100-517	2.2U	Capacitor, Tantalum, 35V, 20%, Rad
C 903	5-00487-574	68P 500V	SMT, High Voltage Porcelain Cap.
C 904	5-00479-574	18P 500V	SMT, High Voltage Porcelain Cap.
C 905	5-00479-574	18P 500V	SMT, High Voltage Porcelain Cap.
C 906	5-00487-574	68P 500V	SMT, High Voltage Porcelain Cap.
D 100	3-00803-360	MMBV609	Integrated Circuit (Surface Mount Pkg)
D 101	3-00648-360	MBRD660CT	Integrated Circuit (Surface Mount Pkg)
D 102	3-00648-360	MBRD660CT	Integrated Circuit (Surface Mount Pkg)
D 202	3-00538-360	MMBD352L	Integrated Circuit (Surface Mount Pkg)

<u>REF.</u>	<u>SRS PART</u>	<u>VALUE</u>	<u>DESCRIPTION</u>
D 203	3-00854-313	ZMM5230B	Diode, SMT
D 204	3-00854-313	ZMM5230B	Diode, SMT
D 205	3-00854-313	ZMM5230B	Diode, SMT
D 400	3-00803-360	MMBV609	Integrated Circuit (Surface Mount Pkg)
D 401	3-00803-360	MMBV609	Integrated Circuit (Surface Mount Pkg)
D 500	3-00648-360	MBRD660CT	Integrated Circuit (Surface Mount Pkg)
D 501	3-00806-360	BAV170LT1	Integrated Circuit (Surface Mount Pkg)
D 502	3-00649-360	BAW56LT1	Integrated Circuit (Surface Mount Pkg)
D 503	3-00544-360	BAV70LT1	Integrated Circuit (Surface Mount Pkg)
D 504	3-00806-360	BAV170LT1	Integrated Circuit (Surface Mount Pkg)
D 700	3-00235-308	47402-15	Diode, Step Recovery
J 100	1-00319-166	10 PIN MALE	Connector, D-Sub, Male
J 100X	1-00320-100	COAX INSERT	Connector, Misc.
J 400	1-00224-141	STRAIGHT PLUG	SMB Connector
J 700	1-00222-141	REAR MT JACK	SMB Connector
J 701	1-00222-141	REAR MT JACK	SMB Connector
J 800	6-00017-630	FB43-301	Ferrite Beads
J 801	6-00017-630	FB43-301	Ferrite Beads
J 802	6-00017-630	FB43-301	Ferrite Beads
JP500	1-00323-130	64 PIN STRIP	Connector, Male
JP501	1-00324-130	64 HDR PIN R/A	Connector, Male
L 100	6-00171-606	4.7UH-5PH	Inductor, Variable
L 101	6-00171-606	4.7UH-5PH	Inductor, Variable
L 102	6-00264-609	100UH - SMT	Inductor, Fixed, SMT
L 103	6-00264-609	100UH - SMT	Inductor, Fixed, SMT
L 104	6-00174-630	6611 TYPE 43	Ferrite Beads
L 105	6-00174-630	6611 TYPE 43	Ferrite Beads
L 200	6-00236-631	FR47	Ferrite bead, SMT
L 300	6-00236-631	FR47	Ferrite bead, SMT
L 301	6-00236-631	FR47	Ferrite bead, SMT
L 302	6-00236-631	FR47	Ferrite bead, SMT
L 400	6-00530-609	.027UH - SMT	Inductor, Fixed, SMT
L 401	6-00513-609	.012UH - SMT	Inductor, Fixed, SMT
L 402	6-00266-609	.18UH - SMT	Inductor, Fixed, SMT
L 403	6-00281-609	2.2U - SMT	Inductor, Fixed, SMT
L 902	6-00011-603	1.0U	Inductor, Axial
LX104	0-00772-000	1.5" WIRE	Hardware, Misc.
LX105	0-00772-000	1.5" WIRE	Hardware, Misc.
P 100	4-01576-459	50K 9MM SIDE	Pot, Multi-Turn Cermet, Various sizes
PC1	7-00767-701	RB MULTIPLES	Printed Circuit Board
Q 100	3-00808-360	MMBR5179	Integrated Circuit (Surface Mount Pkg)
Q 101	3-00555-360	MMBR941L	Integrated Circuit (Surface Mount Pkg)
Q 150	3-00325-329	TIP107	Voltage Reg., TO-220 (TAB) Package
Q 400	3-00895-360	NE461M02	Integrated Circuit (Surface Mount Pkg)
Q 500	3-00807-360	MJD47	Integrated Circuit (Surface Mount Pkg)
Q 501	3-00540-360	MMBT5087	Integrated Circuit (Surface Mount Pkg)
Q 502	3-00808-360	MMBR5179	Integrated Circuit (Surface Mount Pkg)
Q 503	3-00809-360	MMBTH81LT1	Integrated Circuit (Surface Mount Pkg)
Q 504	3-00810-360	MMBTH10LT1	Integrated Circuit (Surface Mount Pkg)
Q 600	3-00325-329	TIP107	Voltage Reg., TO-220 (TAB) Package

<u>REF.</u>	<u>SRS PART</u>	<u>VALUE</u>	<u>DESCRIPTION</u>
Q 800	3-00325-329	TIP107	Voltage Reg., TO-220 (TAB) Package
Q 900	3-00665-360	MRF134	Integrated Circuit (Surface Mount Pkg)
R 100	4-01242-462	20.0K	Thin Film, 1%, 50 ppm, MELF Resistor
R 101	4-01184-462	4.99K	Thin Film, 1%, 50 ppm, MELF Resistor
R 102	4-01309-462	100K	Thin Film, 1%, 50 ppm, MELF Resistor
R 103	4-00954-462	20	Thin Film, 1%, 50 ppm, MELF Resistor
R 104	4-01280-462	49.9K	Thin Film, 1%, 50 ppm, MELF Resistor
R 105	4-01213-462	10.0K	Thin Film, 1%, 50 ppm, MELF Resistor
R 106	4-01447-461	47	Thick Film, 5%, 200 ppm, Chip Resistor
R 107	4-01088-462	499	Thin Film, 1%, 50 ppm, MELF Resistor
R 108	4-01184-462	4.99K	Thin Film, 1%, 50 ppm, MELF Resistor
R 109	4-01213-462	10.0K	Thin Film, 1%, 50 ppm, MELF Resistor
R 110	4-01184-462	4.99K	Thin Film, 1%, 50 ppm, MELF Resistor
R 111	4-01067-462	301	Thin Film, 1%, 50 ppm, MELF Resistor
R 112	4-01447-461	47	Thick Film, 5%, 200 ppm, Chip Resistor
R 113	4-01146-462	2.00K	Thin Film, 1%, 50 ppm, MELF Resistor
R 114	4-01096-462	604	Thin Film, 1%, 50 ppm, MELF Resistor
R 115	4-01251-462	24.9K	Thin Film, 1%, 50 ppm, MELF Resistor
R 116	4-01251-462	24.9K	Thin Film, 1%, 50 ppm, MELF Resistor
R 117	4-01479-461	1.0K	Thick Film, 5%, 200 ppm, Chip Resistor
R 118	4-01503-461	10K	Thick Film, 5%, 200 ppm, Chip Resistor
R 119	4-01503-461	10K	Thick Film, 5%, 200 ppm, Chip Resistor
R 120	4-01503-461	10K	Thick Film, 5%, 200 ppm, Chip Resistor
R 121	4-01213-462	10.0K	Thin Film, 1%, 50 ppm, MELF Resistor
R 123	4-00925-462	10	Thin Film, 1%, 50 ppm, MELF Resistor
R 150	4-01407-461	1	Thick Film, 5%, 200 ppm, Chip Resistor
R 151	4-01407-461	1	Thick Film, 5%, 200 ppm, Chip Resistor
R 153	4-00899-431	PIH104-T-NTC	Thermistor, various
R 154	4-00899-431	PIH104-T-NTC	Thermistor, various
R 200	4-01280-462	49.9K	Thin Film, 1%, 50 ppm, MELF Resistor
R 201	4-01305-462	90.9K	Thin Film, 1%, 50 ppm, MELF Resistor
R 202	4-01295-462	71.5K	Thin Film, 1%, 50 ppm, MELF Resistor
R 203	4-01213-462	10.0K	Thin Film, 1%, 50 ppm, MELF Resistor
R 204	4-01557-461	1.8M	Thick Film, 5%, 200 ppm, Chip Resistor
R 205	4-01575-461	10M	Thick Film, 5%, 200 ppm, Chip Resistor
R 206	4-01213-462	10.0K	Thin Film, 1%, 50 ppm, MELF Resistor
R 207	4-01376-462	499K	Thin Film, 1%, 50 ppm, MELF Resistor
R 208	4-01230-462	15.0K	Thin Film, 1%, 50 ppm, MELF Resistor
R 209	4-01280-462	49.9K	Thin Film, 1%, 50 ppm, MELF Resistor
R 210	4-01230-462	15.0K	Thin Film, 1%, 50 ppm, MELF Resistor
R 211	4-01278-462	47.5K	Thin Film, 1%, 50 ppm, MELF Resistor
R 213	4-01280-462	49.9K	Thin Film, 1%, 50 ppm, MELF Resistor
R 214	4-01305-462	90.9K	Thin Film, 1%, 50 ppm, MELF Resistor
R 215	4-01309-462	100K	Thin Film, 1%, 50 ppm, MELF Resistor
R 216	4-01213-462	10.0K	Thin Film, 1%, 50 ppm, MELF Resistor
R 217	4-01557-461	1.8M	Thick Film, 5%, 200 ppm, Chip Resistor
R 218	4-01575-461	10M	Thick Film, 5%, 200 ppm, Chip Resistor
R 219	4-01213-462	10.0K	Thin Film, 1%, 50 ppm, MELF Resistor
R 220	4-01376-462	499K	Thin Film, 1%, 50 ppm, MELF Resistor
R 221	4-01230-462	15.0K	Thin Film, 1%, 50 ppm, MELF Resistor

<u>REF.</u>	<u>SRS PART</u>	<u>VALUE</u>	<u>DESCRIPTION</u>
R 222	4-01280-462	49.9K	Thin Film, 1%, 50 ppm, MELF Resistor
R 223	4-01230-462	15.0K	Thin Film, 1%, 50 ppm, MELF Resistor
R 224	4-01278-462	47.5K	Thin Film, 1%, 50 ppm, MELF Resistor
R 226	4-01238-462	18.2K	Thin Film, 1%, 50 ppm, MELF Resistor
R 227	4-01305-462	90.9K	Thin Film, 1%, 50 ppm, MELF Resistor
R 228	4-01363-462	365K	Thin Film, 1%, 50 ppm, MELF Resistor
R 229	4-01213-462	10.0K	Thin Film, 1%, 50 ppm, MELF Resistor
R 230	4-01557-461	1.8M	Thick Film, 5%, 200 ppm, Chip Resistor
R 231	4-01575-461	10M	Thick Film, 5%, 200 ppm, Chip Resistor
R 232	4-01213-462	10.0K	Thin Film, 1%, 50 ppm, MELF Resistor
R 233	4-01309-462	100K	Thin Film, 1%, 50 ppm, MELF Resistor
R 234	4-01376-462	499K	Thin Film, 1%, 50 ppm, MELF Resistor
R 235	4-01251-462	24.9K	Thin Film, 1%, 50 ppm, MELF Resistor
R 236	4-01280-462	49.9K	Thin Film, 1%, 50 ppm, MELF Resistor
R 237	4-01251-462	24.9K	Thin Film, 1%, 50 ppm, MELF Resistor
R 238	4-01278-462	47.5K	Thin Film, 1%, 50 ppm, MELF Resistor
R 240	4-01479-461	1.0K	Thick Film, 5%, 200 ppm, Chip Resistor
R 241	4-01117-462	1.00K	Thin Film, 1%, 50 ppm, MELF Resistor
R 248	4-01439-461	22	Thick Film, 5%, 200 ppm, Chip Resistor
R 249	4-01059-462	249	Thin Film, 1%, 50 ppm, MELF Resistor
R 250	4-01479-461	1.0K	Thick Film, 5%, 200 ppm, Chip Resistor
R 252	4-01479-461	1.0K	Thick Film, 5%, 200 ppm, Chip Resistor
R 256	4-01503-461	10K	Thick Film, 5%, 200 ppm, Chip Resistor
R 261	4-01355-462	301K	Thin Film, 1%, 50 ppm, MELF Resistor
R 262	4-01355-462	301K	Thin Film, 1%, 50 ppm, MELF Resistor
R 263	4-01309-462	100K	Thin Film, 1%, 50 ppm, MELF Resistor
R 264	4-01309-462	100K	Thin Film, 1%, 50 ppm, MELF Resistor
R 265	4-01098-462	634	Thin Film, 1%, 50 ppm, MELF Resistor
R 266	4-01309-462	100K	Thin Film, 1%, 50 ppm, MELF Resistor
R 267	4-01309-462	100K	Thin Film, 1%, 50 ppm, MELF Resistor
R 268	4-01405-462	1.00M	Thin Film, 1%, 50 ppm, MELF Resistor
R 269	4-01280-462	49.9K	Thin Film, 1%, 50 ppm, MELF Resistor
R 270	4-01347-462	249K	Thin Film, 1%, 50 ppm, MELF Resistor
R 271	4-01213-462	10.0K	Thin Film, 1%, 50 ppm, MELF Resistor
R 272	4-01280-462	49.9K	Thin Film, 1%, 50 ppm, MELF Resistor
R 273	4-01455-461	100	Thick Film, 5%, 200 ppm, Chip Resistor
R 274	4-01191-462	5.90K	Thin Film, 1%, 50 ppm, MELF Resistor
R 275	4-01213-462	10.0K	Thin Film, 1%, 50 ppm, MELF Resistor
R 276	4-01305-462	90.9K	Thin Film, 1%, 50 ppm, MELF Resistor
R 277	4-01213-462	10.0K	Thin Film, 1%, 50 ppm, MELF Resistor
R 278	4-01305-462	90.9K	Thin Film, 1%, 50 ppm, MELF Resistor
R 279	4-01213-462	10.0K	Thin Film, 1%, 50 ppm, MELF Resistor
R 280	4-01305-462	90.9K	Thin Film, 1%, 50 ppm, MELF Resistor
R 281	4-01213-462	10.0K	Thin Film, 1%, 50 ppm, MELF Resistor
R 282	4-01305-462	90.9K	Thin Film, 1%, 50 ppm, MELF Resistor
R 283	4-01213-462	10.0K	Thin Film, 1%, 50 ppm, MELF Resistor
R 284	4-01294-462	69.8K	Thin Film, 1%, 50 ppm, MELF Resistor
R 285	4-01280-462	49.9K	Thin Film, 1%, 50 ppm, MELF Resistor
R 286	4-01294-462	69.8K	Thin Film, 1%, 50 ppm, MELF Resistor
R 287	4-01280-462	49.9K	Thin Film, 1%, 50 ppm, MELF Resistor

<u>REF.</u>	<u>SRS PART</u>	<u>VALUE</u>	<u>DESCRIPTION</u>
R 288	4-01294-462	69.8K	Thin Film, 1%, 50 ppm, MELF Resistor
R 289	4-01280-462	49.9K	Thin Film, 1%, 50 ppm, MELF Resistor
R 290	4-01479-461	1.0K	Thick Film, 5%, 200 ppm, Chip Resistor
R 291	4-01575-461	10M	Thick Film, 5%, 200 ppm, Chip Resistor
R 292	4-01479-461	1.0K	Thick Film, 5%, 200 ppm, Chip Resistor
R 293	4-01213-462	10.0K	Thin Film, 1%, 50 ppm, MELF Resistor
R 294	4-01251-462	24.9K	Thin Film, 1%, 50 ppm, MELF Resistor
R 295	4-01575-461	10M	Thick Film, 5%, 200 ppm, Chip Resistor
R 296	4-01213-462	10.0K	Thin Film, 1%, 50 ppm, MELF Resistor
R 297	4-01280-462	49.9K	Thin Film, 1%, 50 ppm, MELF Resistor
R 298	4-01213-462	10.0K	Thin Film, 1%, 50 ppm, MELF Resistor
R 299	4-01280-462	49.9K	Thin Film, 1%, 50 ppm, MELF Resistor
R 300	4-01405-462	1.00M	Thin Film, 1%, 50 ppm, MELF Resistor
R 301	4-01302-462	84.5K	Thin Film, 1%, 50 ppm, MELF Resistor
R 303	4-01479-461	1.0K	Thick Film, 5%, 200 ppm, Chip Resistor
R 304	4-01479-461	1.0K	Thick Film, 5%, 200 ppm, Chip Resistor
R 305	4-01527-461	100K	Thick Film, 5%, 200 ppm, Chip Resistor
R 324	4-01249-462	23.7K	Thin Film, 1%, 50 ppm, MELF Resistor
R 325	4-01230-462	15.0K	Thin Film, 1%, 50 ppm, MELF Resistor
R 326	4-01213-462	10.0K	Thin Film, 1%, 50 ppm, MELF Resistor
R 327	4-01455-461	100	Thick Film, 5%, 200 ppm, Chip Resistor
R 329	4-01455-461	100	Thick Film, 5%, 200 ppm, Chip Resistor
R 331	4-01073-462	348	Thin Film, 1%, 50 ppm, MELF Resistor
R 332	4-01117-462	1.00K	Thin Film, 1%, 50 ppm, MELF Resistor
R 333	4-01405-462	1.00M	Thin Film, 1%, 50 ppm, MELF Resistor
R 334	4-01251-462	24.9K	Thin Film, 1%, 50 ppm, MELF Resistor
R 335	4-01213-462	10.0K	Thin Film, 1%, 50 ppm, MELF Resistor
R 336	4-01575-461	10M	Thick Film, 5%, 200 ppm, Chip Resistor
R 337	4-01455-461	100	Thick Film, 5%, 200 ppm, Chip Resistor
R 338	4-01503-461	10K	Thick Film, 5%, 200 ppm, Chip Resistor
R 339	4-01479-461	1.0K	Thick Film, 5%, 200 ppm, Chip Resistor
R 340	4-01479-461	1.0K	Thick Film, 5%, 200 ppm, Chip Resistor
R 341	4-01503-461	10K	Thick Film, 5%, 200 ppm, Chip Resistor
R 342	4-01479-461	1.0K	Thick Film, 5%, 200 ppm, Chip Resistor
R 343	4-01503-461	10K	Thick Film, 5%, 200 ppm, Chip Resistor
R 344	4-01464-461	240	Thick Film, 5%, 200 ppm, Chip Resistor
R 345	4-01464-461	240	Thick Film, 5%, 200 ppm, Chip Resistor
R 346	4-01464-461	240	Thick Film, 5%, 200 ppm, Chip Resistor
R 347	4-01464-461	240	Thick Film, 5%, 200 ppm, Chip Resistor
R 348	0-00000-000	UNDECIDED PART	Hardware, Misc.
R 349	4-01464-461	240	Thick Film, 5%, 200 ppm, Chip Resistor
R 350	4-01464-461	240	Thick Film, 5%, 200 ppm, Chip Resistor
R 351	4-01464-461	240	Thick Film, 5%, 200 ppm, Chip Resistor
R 352	4-01464-461	240	Thick Film, 5%, 200 ppm, Chip Resistor
R 353	0-00000-000	UNDECIDED PART	Hardware, Misc.
R 354	4-01493-461	3.9K	Thick Film, 5%, 200 ppm, Chip Resistor
R 355	4-01527-461	100K	Thick Film, 5%, 200 ppm, Chip Resistor
R 356	4-01493-461	3.9K	Thick Film, 5%, 200 ppm, Chip Resistor
R 357	4-01527-461	100K	Thick Film, 5%, 200 ppm, Chip Resistor
R 358	0-00000-000	UNDECIDED PART	Hardware, Misc.

<u>REF.</u>	<u>SRS PART</u>	<u>VALUE</u>	<u>DESCRIPTION</u>
R 359	0-00000-000	UNDECIDED PART	Hardware, Misc.
R 360	4-01213-462	10.0K	Thin Film, 1%, 50 ppm, MELF Resistor
R 400	4-01347-462	249K	Thin Film, 1%, 50 ppm, MELF Resistor
R 401	4-01405-462	1.00M	Thin Film, 1%, 50 ppm, MELF Resistor
R 402	4-01447-461	47	Thick Film, 5%, 200 ppm, Chip Resistor
R 403	4-01463-461	220	Thick Film, 5%, 200 ppm, Chip Resistor
R 404	4-01527-461	100K	Thick Film, 5%, 200 ppm, Chip Resistor
R 405	4-01201-462	7.50K	Thin Film, 1%, 50 ppm, MELF Resistor
R 406	4-01561-461	2.7M	Thick Film, 5%, 200 ppm, Chip Resistor
R 407	4-01213-462	10.0K	Thin Film, 1%, 50 ppm, MELF Resistor
R 408	4-01259-462	30.1K	Thin Film, 1%, 50 ppm, MELF Resistor
R 409	4-01355-462	301K	Thin Film, 1%, 50 ppm, MELF Resistor
R 410	4-01309-462	100K	Thin Film, 1%, 50 ppm, MELF Resistor
R 411	4-01527-461	100K	Thick Film, 5%, 200 ppm, Chip Resistor
R 412	4-01088-462	499	Thin Film, 1%, 50 ppm, MELF Resistor
R 413	4-01088-462	499	Thin Film, 1%, 50 ppm, MELF Resistor
R 414	4-01088-462	499	Thin Film, 1%, 50 ppm, MELF Resistor
R 415	4-01251-462	24.9K	Thin Film, 1%, 50 ppm, MELF Resistor
R 416	4-01251-462	24.9K	Thin Film, 1%, 50 ppm, MELF Resistor
R 417	4-01117-462	1.00K	Thin Film, 1%, 50 ppm, MELF Resistor
R 418	4-01117-462	1.00K	Thin Film, 1%, 50 ppm, MELF Resistor
R 419	4-01467-461	330	Thick Film, 5%, 200 ppm, Chip Resistor
R 420	4-01467-461	330	Thick Film, 5%, 200 ppm, Chip Resistor
R 421	4-01465-461	270	Thick Film, 5%, 200 ppm, Chip Resistor
R 422	4-01355-462	301K	Thin Film, 1%, 50 ppm, MELF Resistor
R 423	4-01309-462	100K	Thin Film, 1%, 50 ppm, MELF Resistor
R 424	4-01479-461	1.0K	Thick Film, 5%, 200 ppm, Chip Resistor
R 425	4-01471-461	470	Thick Film, 5%, 200 ppm, Chip Resistor
R 426	4-01479-461	1.0K	Thick Film, 5%, 200 ppm, Chip Resistor
R 427	4-01479-461	1.0K	Thick Film, 5%, 200 ppm, Chip Resistor
R 428	4-01447-461	47	Thick Film, 5%, 200 ppm, Chip Resistor
R 429	4-01503-461	10K	Thick Film, 5%, 200 ppm, Chip Resistor
R 430	4-01280-462	49.9K	Thin Film, 1%, 50 ppm, MELF Resistor
R 431	4-01117-462	1.00K	Thin Film, 1%, 50 ppm, MELF Resistor
R 432	4-01447-461	47	Thick Film, 5%, 200 ppm, Chip Resistor
R 433	4-01447-461	47	Thick Film, 5%, 200 ppm, Chip Resistor
R 434	4-01447-461	47	Thick Film, 5%, 200 ppm, Chip Resistor
R 435	4-01213-462	10.0K	Thin Film, 1%, 50 ppm, MELF Resistor
R 436	4-01280-462	49.9K	Thin Film, 1%, 50 ppm, MELF Resistor
R 437	4-01503-461	10K	Thick Film, 5%, 200 ppm, Chip Resistor
R 438	4-01355-462	301K	Thin Film, 1%, 50 ppm, MELF Resistor
R 439	4-01309-462	100K	Thin Film, 1%, 50 ppm, MELF Resistor
R 440	4-01280-462	49.9K	Thin Film, 1%, 50 ppm, MELF Resistor
R 441	4-01213-462	10.0K	Thin Film, 1%, 50 ppm, MELF Resistor
R 442	4-01184-462	4.99K	Thin Film, 1%, 50 ppm, MELF Resistor
R 443	4-01439-461	22	Thick Film, 5%, 200 ppm, Chip Resistor
R 444	4-00992-462	49.9	Thin Film, 1%, 50 ppm, MELF Resistor
R 445	4-01511-461	22K	Thick Film, 5%, 200 ppm, Chip Resistor
R 446	4-01503-461	10K	Thick Film, 5%, 200 ppm, Chip Resistor
R 447	4-01455-461	100	Thick Film, 5%, 200 ppm, Chip Resistor

<u>REF.</u>	<u>SRS PART</u>	<u>VALUE</u>	<u>DESCRIPTION</u>
R 448	4-01447-461	47	Thick Film, 5%, 200 ppm, Chip Resistor
R 449	4-01551-461	1.0M	Thick Film, 5%, 200 ppm, Chip Resistor
R 450	4-01439-461	22	Thick Film, 5%, 200 ppm, Chip Resistor
R 500	4-01059-462	249	Thin Film, 1%, 50 ppm, MELF Resistor
R 501	4-01021-462	100	Thin Film, 1%, 50 ppm, MELF Resistor
R 502	4-01280-462	49.9K	Thin Film, 1%, 50 ppm, MELF Resistor
R 503	4-01213-462	10.0K	Thin Film, 1%, 50 ppm, MELF Resistor
R 504	4-00925-462	10	Thin Film, 1%, 50 ppm, MELF Resistor
R 505	4-00925-462	10	Thin Film, 1%, 50 ppm, MELF Resistor
R 506	4-01213-462	10.0K	Thin Film, 1%, 50 ppm, MELF Resistor
R 507	4-01213-462	10.0K	Thin Film, 1%, 50 ppm, MELF Resistor
R 508	4-01309-462	100K	Thin Film, 1%, 50 ppm, MELF Resistor
R 509	4-01309-462	100K	Thin Film, 1%, 50 ppm, MELF Resistor
R 510	4-01347-462	249K	Thin Film, 1%, 50 ppm, MELF Resistor
R 511	4-01280-462	49.9K	Thin Film, 1%, 50 ppm, MELF Resistor
R 512	4-01479-461	1.0K	Thick Film, 5%, 200 ppm, Chip Resistor
R 513	4-01059-462	249	Thin Film, 1%, 50 ppm, MELF Resistor
R 514	4-01167-462	3.32K	Thin Film, 1%, 50 ppm, MELF Resistor
R 515	4-01487-461	2.2K	Thick Film, 5%, 200 ppm, Chip Resistor
R 516	4-01213-462	10.0K	Thin Film, 1%, 50 ppm, MELF Resistor
R 517	4-01405-462	1.00M	Thin Film, 1%, 50 ppm, MELF Resistor
R 518	4-01242-462	20.0K	Thin Film, 1%, 50 ppm, MELF Resistor
R 519	4-01146-462	2.00K	Thin Film, 1%, 50 ppm, MELF Resistor
R 520	4-01088-462	499	Thin Film, 1%, 50 ppm, MELF Resistor
R 521	4-01230-462	15.0K	Thin Film, 1%, 50 ppm, MELF Resistor
R 522	4-01117-462	1.00K	Thin Film, 1%, 50 ppm, MELF Resistor
R 523	4-01251-462	24.9K	Thin Film, 1%, 50 ppm, MELF Resistor
R 524	4-01447-461	47	Thick Film, 5%, 200 ppm, Chip Resistor
R 525	4-01479-461	1.0K	Thick Film, 5%, 200 ppm, Chip Resistor
R 526	4-01242-462	20.0K	Thin Film, 1%, 50 ppm, MELF Resistor
R 527	4-01230-462	15.0K	Thin Film, 1%, 50 ppm, MELF Resistor
R 528	4-01213-462	10.0K	Thin Film, 1%, 50 ppm, MELF Resistor
R 529	4-01213-462	10.0K	Thin Film, 1%, 50 ppm, MELF Resistor
R 530	4-01213-462	10.0K	Thin Film, 1%, 50 ppm, MELF Resistor
R 531	4-01213-462	10.0K	Thin Film, 1%, 50 ppm, MELF Resistor
R 532	4-01213-462	10.0K	Thin Film, 1%, 50 ppm, MELF Resistor
R 533	4-01493-461	3.9K	Thick Film, 5%, 200 ppm, Chip Resistor
R 534	4-01213-462	10.0K	Thin Film, 1%, 50 ppm, MELF Resistor
R 536	4-01213-462	10.0K	Thin Film, 1%, 50 ppm, MELF Resistor
R 537	4-01213-462	10.0K	Thin Film, 1%, 50 ppm, MELF Resistor
R 538	4-01213-462	10.0K	Thin Film, 1%, 50 ppm, MELF Resistor
R 539	4-01489-461	2.7K	Thick Film, 5%, 200 ppm, Chip Resistor
R 540	4-01184-462	4.99K	Thin Film, 1%, 50 ppm, MELF Resistor
R 541	4-01184-462	4.99K	Thin Film, 1%, 50 ppm, MELF Resistor
R 542	4-01184-462	4.99K	Thin Film, 1%, 50 ppm, MELF Resistor
R 543	4-01146-462	2.00K	Thin Film, 1%, 50 ppm, MELF Resistor
R 544	4-01218-462	11.3K	Thin Film, 1%, 50 ppm, MELF Resistor
R 545	4-01117-462	1.00K	Thin Film, 1%, 50 ppm, MELF Resistor
R 546	4-01146-462	2.00K	Thin Film, 1%, 50 ppm, MELF Resistor
R 547	4-01447-461	47	Thick Film, 5%, 200 ppm, Chip Resistor

<u>REF.</u>	<u>SRS PART</u>	<u>VALUE</u>	<u>DESCRIPTION</u>
R 548	4-01469-461	390	Thick Film, 5%, 200 ppm, Chip Resistor
R 550	4-01405-462	1.00M	Thin Film, 1%, 50 ppm, MELF Resistor
R 551	4-01479-461	1.0K	Thick Film, 5%, 200 ppm, Chip Resistor
R 552	4-00925-462	10	Thin Film, 1%, 50 ppm, MELF Resistor
R 553	4-00925-462	10	Thin Film, 1%, 50 ppm, MELF Resistor
R 600	4-01407-461	1	Thick Film, 5%, 200 ppm, Chip Resistor
R 601	4-01407-461	1	Thick Film, 5%, 200 ppm, Chip Resistor
R 602	4-01407-461	1	Thick Film, 5%, 200 ppm, Chip Resistor
R 603	4-00899-431	P1H104-T-NTC	Thermistor, various
R 604	4-00899-431	P1H104-T-NTC	Thermistor, various
R 605	4-01407-461	1	Thick Film, 5%, 200 ppm, Chip Resistor
R 800	4-01407-461	1	Thick Film, 5%, 200 ppm, Chip Resistor
R 801	4-01407-461	1	Thick Film, 5%, 200 ppm, Chip Resistor
R 803	4-00899-431	P1H104-T-NTC	Thermistor, various
R 804	4-00899-431	P1H104-T-NTC	Thermistor, various
R 900	4-01597-405	10K	Resistor, Carbon Film, 1/8W, 5%
RX249	5-00375-552	100P	Capacitor, Chip (SMT1206), 50V, 5%, NPO
T 100	6-00195-610	10.7 MHZ	Transformer
U 100	3-00542-360	AD587JR	Integrated Circuit (Surface Mount Pkg)
U 101	3-00819-360	LM7171AIM	Integrated Circuit (Surface Mount Pkg)
U 102	3-00773-360	LM358	Integrated Circuit (Surface Mount Pkg)
U 150	3-00346-329	7812	Voltage Reg., TO-220 (TAB) Package
U 200	3-00774-360	LMC662C	Integrated Circuit (Surface Mount Pkg)
U 201	3-00774-360	LMC662C	Integrated Circuit (Surface Mount Pkg)
U 202	3-00774-360	LMC662C	Integrated Circuit (Surface Mount Pkg)
U 205	3-00653-360	AD8561AR	Integrated Circuit (Surface Mount Pkg)
U 206	3-00659-360	OP284FS	Integrated Circuit (Surface Mount Pkg)
U 207	3-00774-360	LMC662C	Integrated Circuit (Surface Mount Pkg)
U 208	3-00661-360	74HC4051	Integrated Circuit (Surface Mount Pkg)
U 209	3-00661-360	74HC4051	Integrated Circuit (Surface Mount Pkg)
U 210	3-00581-360	AD822	Integrated Circuit (Surface Mount Pkg)
U 300	3-00563-360	MAX705CSA	Integrated Circuit (Surface Mount Pkg)
U 301	3-00662-360	74HC14	Integrated Circuit (Surface Mount Pkg)
U 303	3-00663-360	74HC08	Integrated Circuit (Surface Mount Pkg)
U 304	3-00662-360	74HC14	Integrated Circuit (Surface Mount Pkg)
U 306	3-00643-360	DG211BDY	Integrated Circuit (Surface Mount Pkg)
U 307	3-00773-360	LM358	Integrated Circuit (Surface Mount Pkg)
U 308	3-00659-360	OP284FS	Integrated Circuit (Surface Mount Pkg)
U 309	3-00581-360	AD822	Integrated Circuit (Surface Mount Pkg)
U 310	3-00652-360	LTC1452CS8	Integrated Circuit (Surface Mount Pkg)
U 311	3-00652-360	LTC1452CS8	Integrated Circuit (Surface Mount Pkg)
U 312	3-00652-360	LTC1452CS8	Integrated Circuit (Surface Mount Pkg)
U 313	3-00652-360	LTC1452CS8	Integrated Circuit (Surface Mount Pkg)
U 314	3-00658-360	AD7896AR	Integrated Circuit (Surface Mount Pkg)
U 400	3-00946-360	MC145193F	Integrated Circuit (Surface Mount Pkg)
U 401	3-00581-360	AD822	Integrated Circuit (Surface Mount Pkg)
U 402	3-00654-360	SA602D	Integrated Circuit (Surface Mount Pkg)
U 403	3-00660-360	OP27GS	Integrated Circuit (Surface Mount Pkg)
U 404	6-00193-625	380 MHZ	Voltage Controlled Crystal Oscillator
U 405	3-00650-360	MC12026AD	Integrated Circuit (Surface Mount Pkg)

<u>REF.</u>	<u>SRS PART</u>	<u>VALUE</u>	<u>DESCRIPTION</u>
U 406	3-00773-360	LM358	Integrated Circuit (Surface Mount Pkg)
U 407	3-00655-360	TLC5628	Integrated Circuit (Surface Mount Pkg)
U 500	3-00751-360	74HC574	Integrated Circuit (Surface Mount Pkg)
U 501	3-00149-329	LM317T	Voltage Reg., TO-220 (TAB) Package
U 502	3-00581-360	AD822	Integrated Circuit (Surface Mount Pkg)
U 503	3-00149-329	LM317T	Voltage Reg., TO-220 (TAB) Package
U 504	3-00112-329	7805	Voltage Reg., TO-220 (TAB) Package
U 505	3-00775-360	LM45CIM3	Integrated Circuit (Surface Mount Pkg)
U 506	3-00742-360	74HC74	Integrated Circuit (Surface Mount Pkg)
U 507	3-00742-360	74HC74	Integrated Circuit (Surface Mount Pkg)
U 508	3-00742-360	74HC74	Integrated Circuit (Surface Mount Pkg)
U 509	3-00813-360	LM311M	Integrated Circuit (Surface Mount Pkg)
U 510	3-00812-360	74HC153	Integrated Circuit (Surface Mount Pkg)
U 511	3-00581-360	AD822	Integrated Circuit (Surface Mount Pkg)
U 512	3-00581-360	AD822	Integrated Circuit (Surface Mount Pkg)
U 514	3-00534-360	AD790JR	Integrated Circuit (Surface Mount Pkg)
U 600	3-00346-329	7812	Voltage Reg., TO-220 (TAB) Package
U 800	3-00561-329	7808	Voltage Reg., TO-220 (TAB) Package
UX205	5-00547-504	2.2P	Capacitor, Chip (SMT0805), 50V, 10%, NPO
Y 100	6-00132-620	10 MHZ SC-CUT	Crystal
Y 400	6-00194-620	22.4825 MHZ	Crystal
Z 0	0-00045-013	4-40 MINI	Nut, Mini
Z 0	0-00096-041	#4 SPLIT	Washer, Split
Z 0	0-00098-042	#6 LOCK	Washer, lock
Z 0	0-00231-043	#4 SHOULDER	Washer, nylon
Z 0	0-00243-003	TO-220	Insulators
Z 0	0-00605-025	4-40X1/4 SOCKET	Screw, Allen Head
Z 0	0-00606-025	4-40X1/4 BUTTON	Screw, Allen Head
Z 0	0-00607-025	4-40X1/2 SOCKET	Screw, Allen Head
Z 0	0-00608-025	6-32X1/4 BUTTON	Screw, Allen Head
Z 0	0-00609-025	6-32X5/8 SOCKET	Screw, Allen Head
Z 0	0-00629-066	FOIL;CU 1/2"	Copper Foil Tape, Self Adhesive
Z 0	0-00630-034	#22 INSULATING	Tubing
Z 0	0-00641-031	4-40X3/16 M/F	Standoff
Z 0	0-00642-031	4-40X3/8 M/F	Standoff
Z 0	0-00643-020	4-40X3/16PF UND	Screw, Flathead Phillips
Z 0	0-00644-020	4-40X1/4PF UNDR	Screw, Flathead Phillips
Z 0	0-00645-055	#34AWG MAGNET	Wire, Other
Z 0	0-00902-034	S/S SEAMLESS	Tubing
Z 0	0-00908-030	PROTO MATERIAL	Spacer
Z 0	0-00915-034	CU TUBING 1/16	Tubing
Z 0	1-00323-130	64 PIN STRIP	Connector, Male
Z 0	1-00324-130	64 HDR PIN R/A	Connector, Male
Z 0	3-00668-312	PHOTODIODE	Photodiode
Z 0	7-00557-717	RB-10	Deep-Drawn or Stamping
Z 0	7-00560-721	RB-1	Machined Part
Z 0	7-00636-720	RB-4	Fabricated Part
Z 0	7-00638-721	RB-6	Machined Part
Z 0	7-00639-721	RB-7	Machined Part
Z 0	7-00641-721	RB-9	Machined Part

<u>REF.</u>	<u>SRS PART</u>	<u>VALUE</u>	<u>DESCRIPTION</u>
Z 0	7-00862-720	RB SPACER	Fabricated Part
Z 0	9-00571-924	SPECIALTY #56	Tape. All types

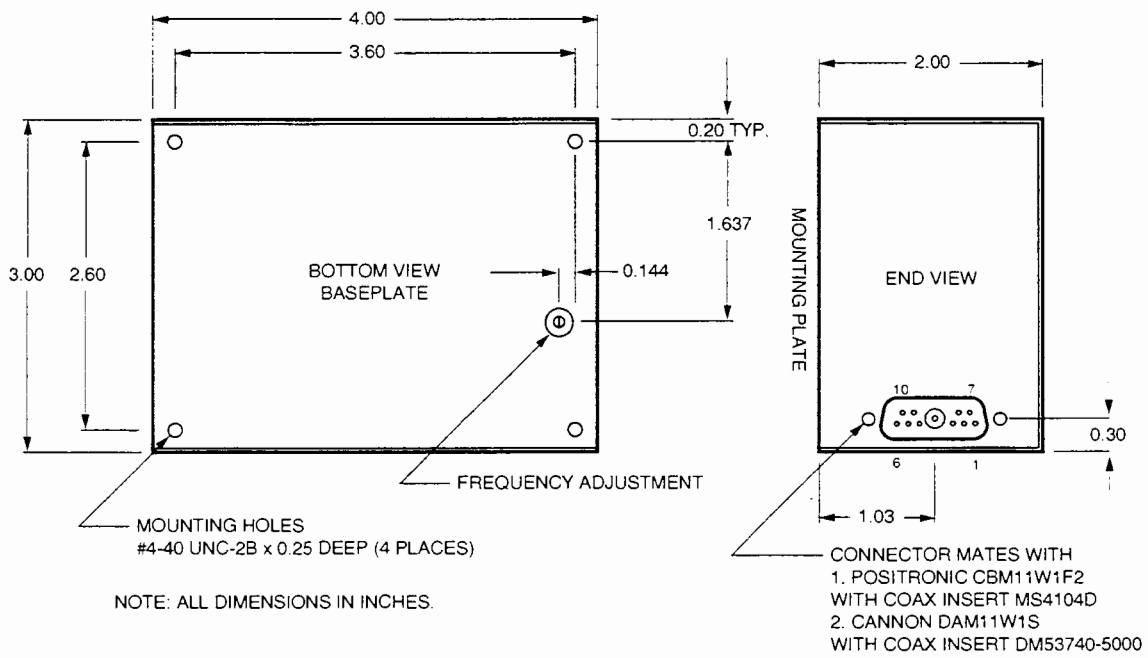
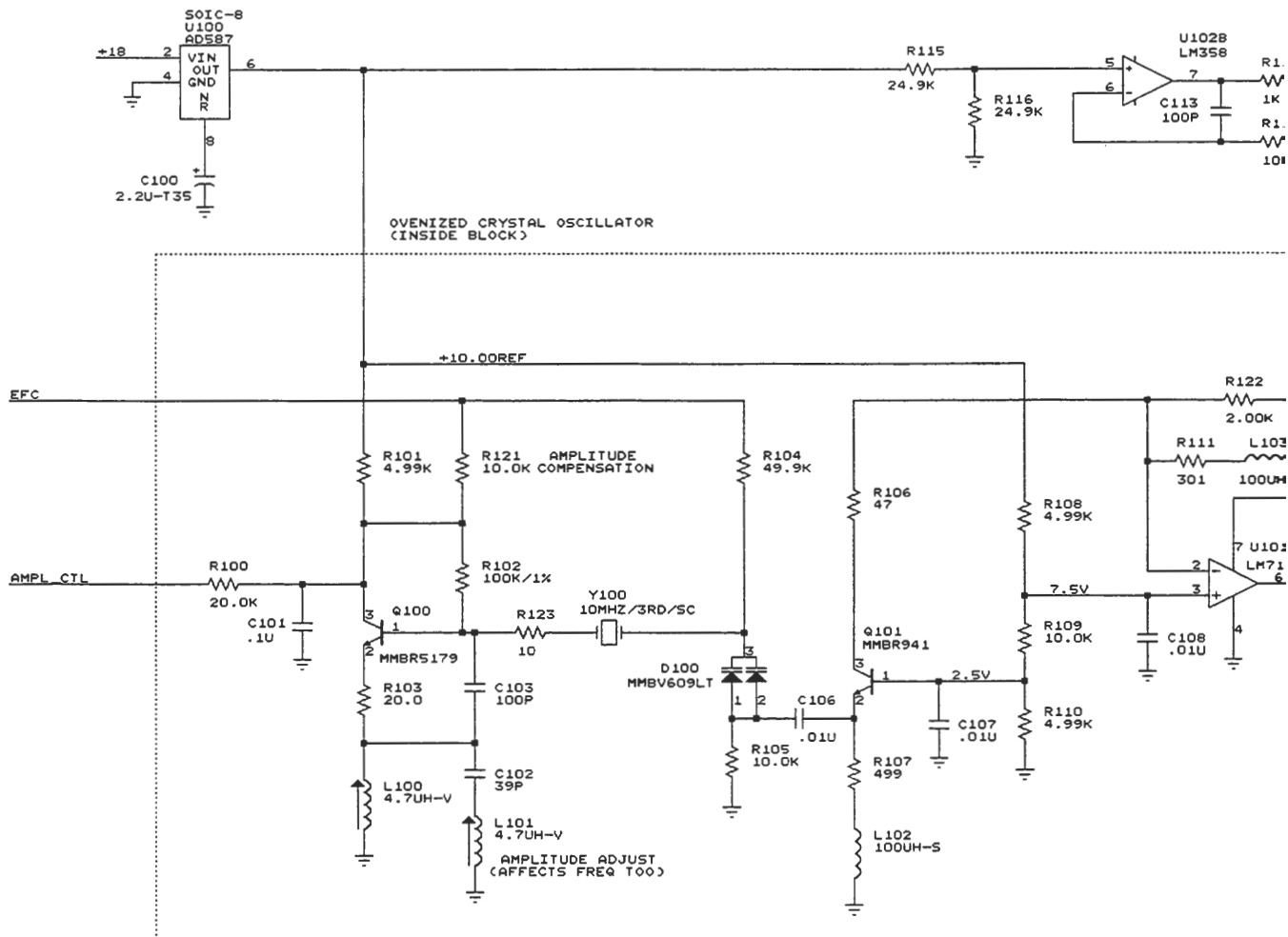
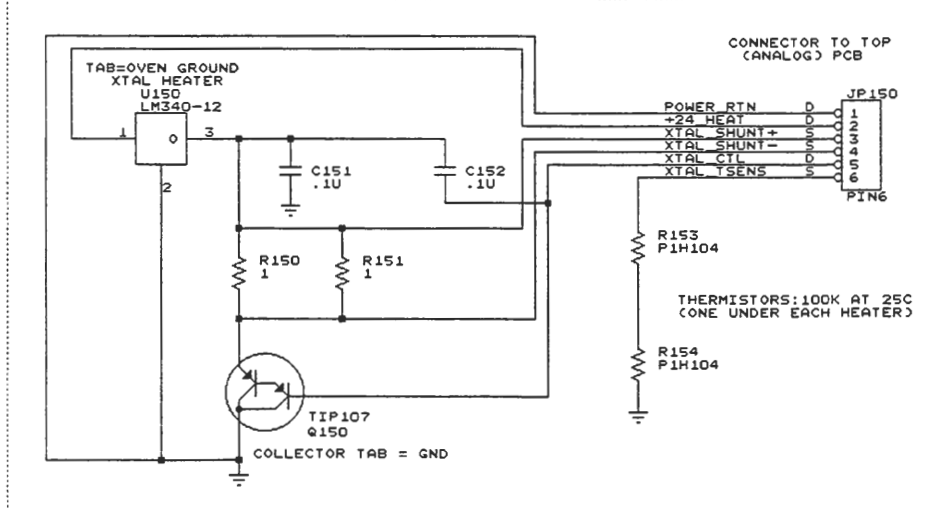
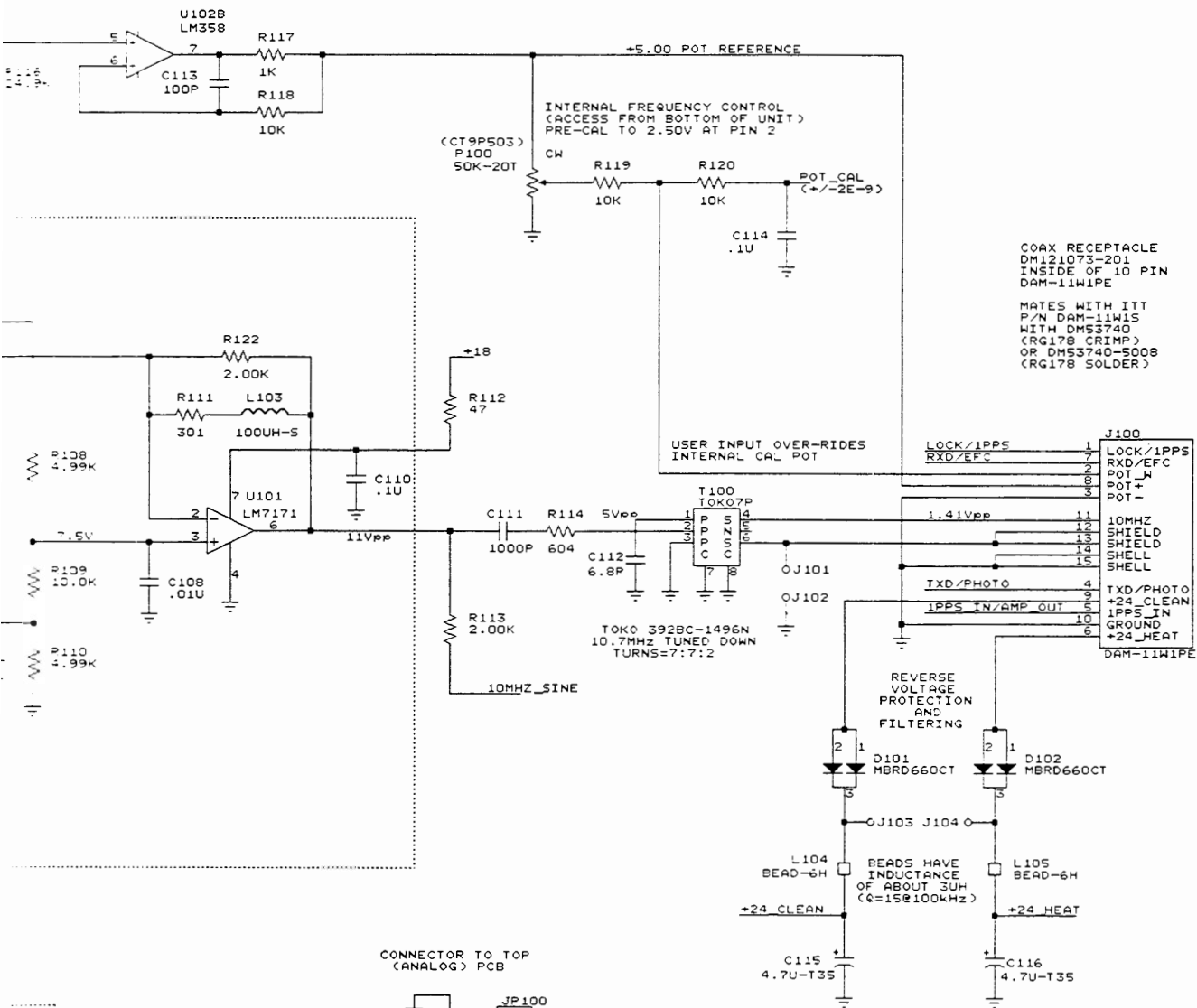

Figure 4. Mechanical Dimensions



HEATER PCB (ON CRYSTAL OVEN LID) (REFERENCE DESIGNATORS START AT 150)





COAX RECEPTACLE
DM121073-201
INSIDE OF 10 PIN
DAM-11W1PE
MATES WITH ITT
P/N DAM-11W1S
WITH DMS3740
(RG178 CRIMP)
OR DMS3740-5008
(RG178 SOLDER)

USER INPUT OVER-RIDES
INTERNAL CAL. POT

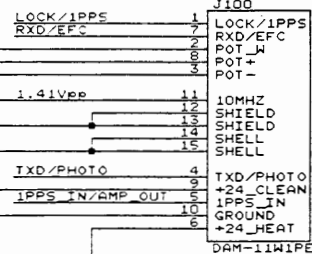

CONNECTOR TO TOP
(ANALOG) PCB

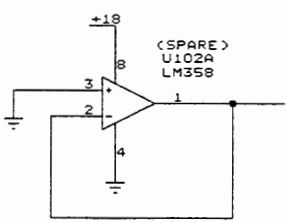
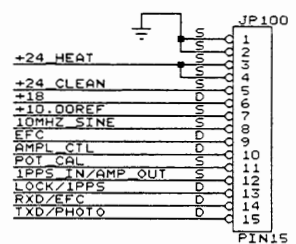

UNLESS OTHERWISE NOTED:

- 1.) ALL CAPS LESS THAN OR EQUAL TO 1000 pF ARE NPO
- 2.) CAPS BETWEEN 1000pF AND .1uF ARE X7R
- 3.) SMD SIZE 1206 (FOR 1/8W POWER RATING FOR RESISTORS)

S=SOURCE OF SIGNAL ON THIS PCB
D=DESTINATION OF SIGNAL IS THIS PCB
P=PASS THROUGH OF SIGNAL ON THIS PCB

STANFORD RESEARCH SYSTEMS			
Title			
10MHz OVENIZED OSCILLATOR			
Size	Document Number		REV
C	RB_H1		H
Date:	August 12, 1999	Sheet	1 of 8

CRYSTAL TEMPERATURE CONTROL

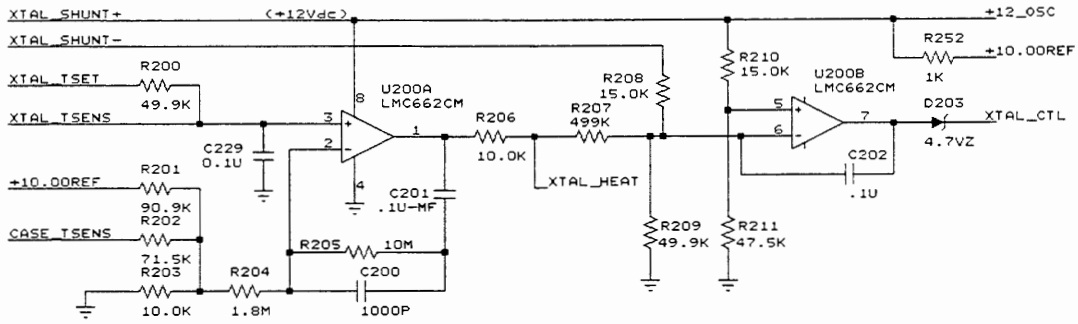

CELL TEMPERATURE CONTROL

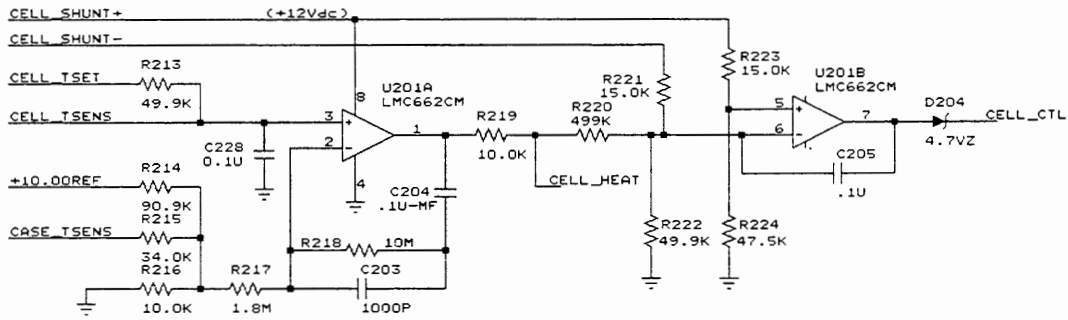

LAMP TEMPERATURE CONTROL

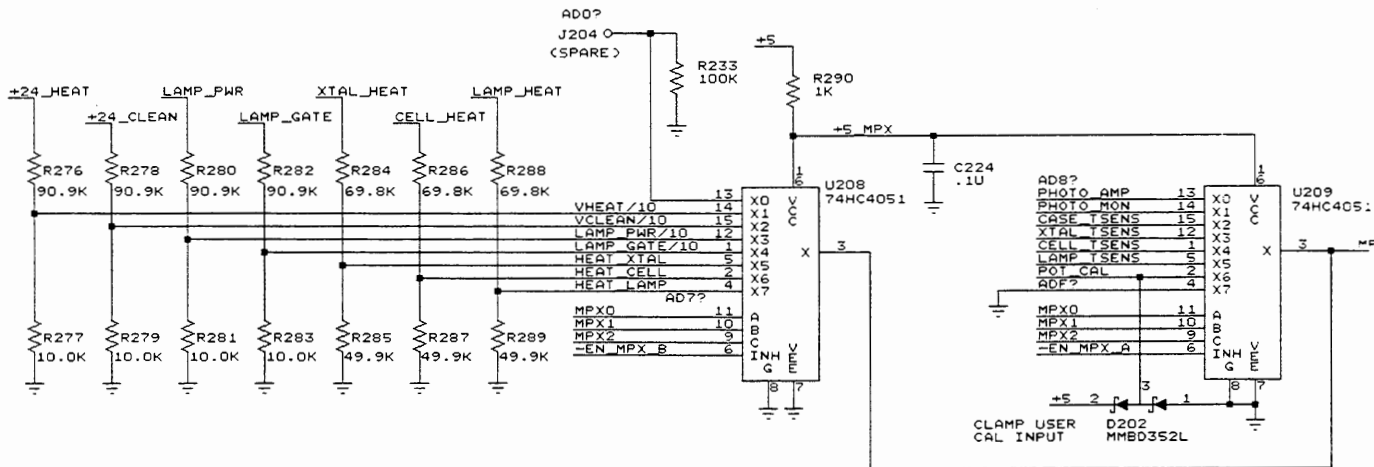
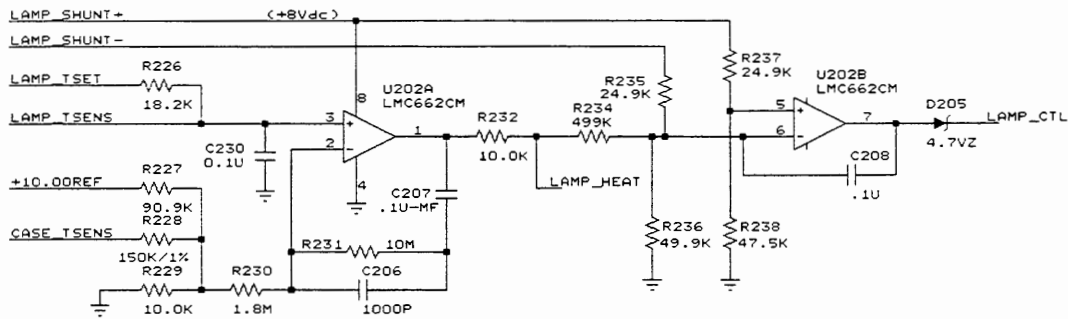

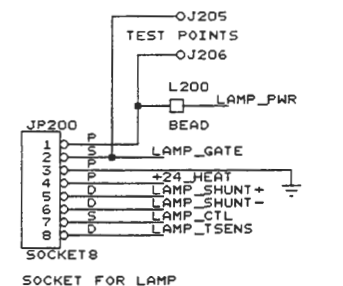
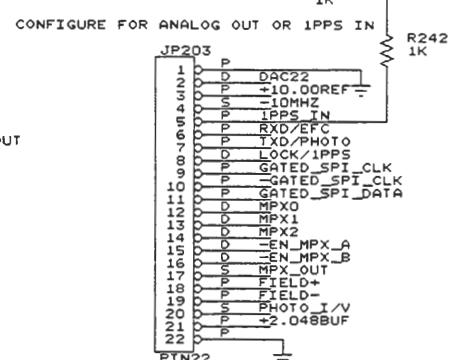
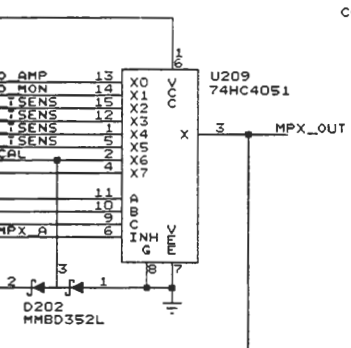
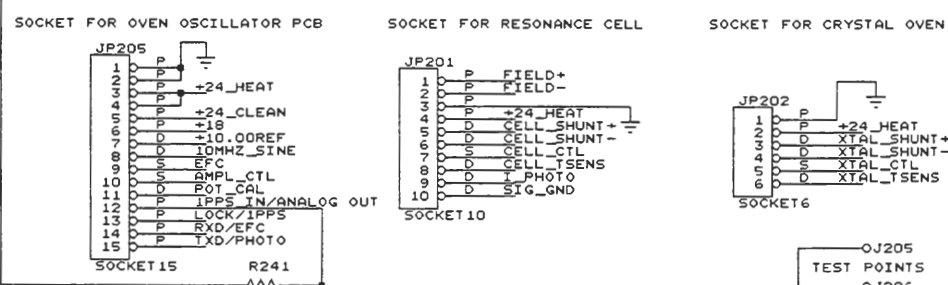
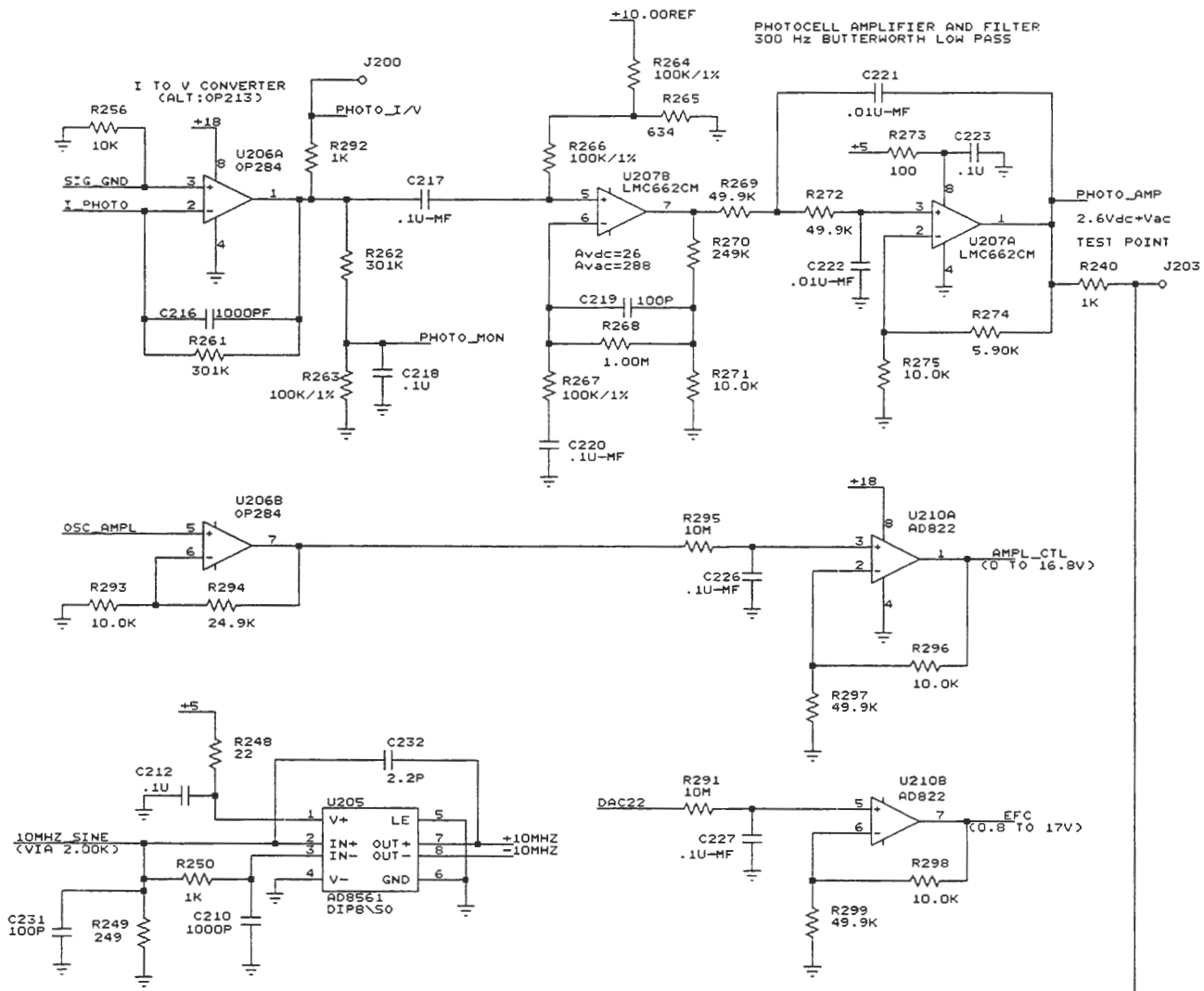

NOTE: ADDED C231 AND C232 AND CHANGED VALUE OF C210 AS OF 9/26/01.

STANFORD RESEARCH SYSTEMS		
Title	TEMPERATURE CONTROL & SIGNAL AMPS (TOP PCB)	
Size	Document Number	REV
C	RB_H2	H
Date:	December 21, 2001	Sheet 2 of 6

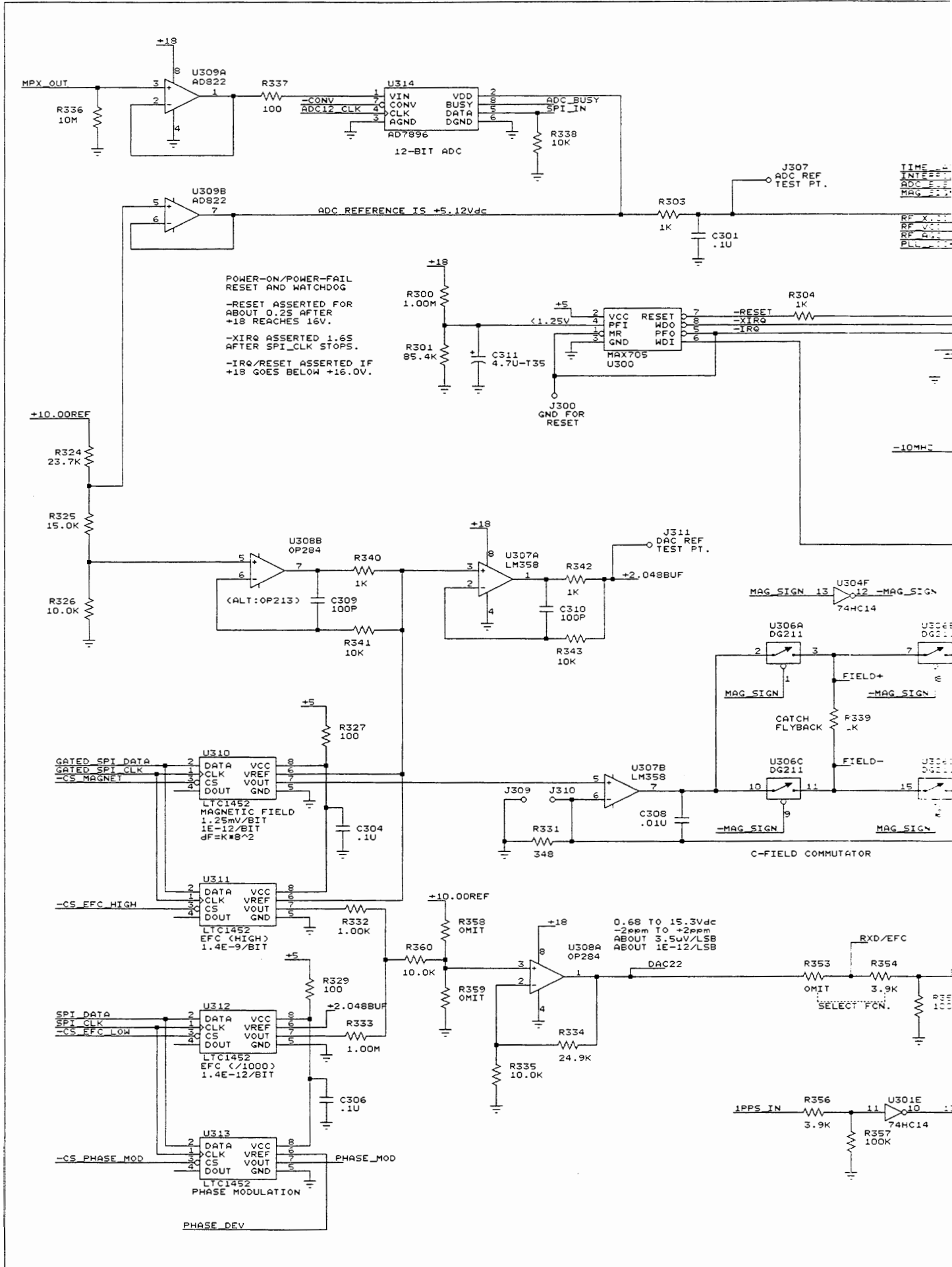

TIME
 INTERF
 ADC REF
 REF VCC
 REF GND
 PLL

-10MHz

C-FIELD COMMUTATOR

RXD/EFC
 SELECT FGN.

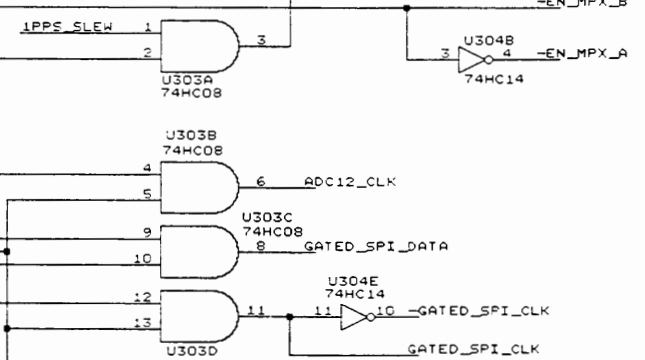
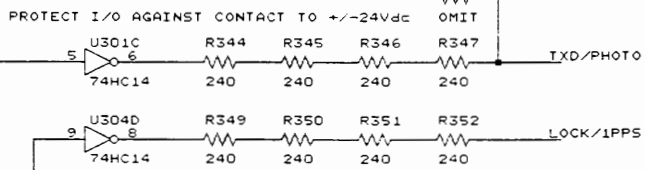
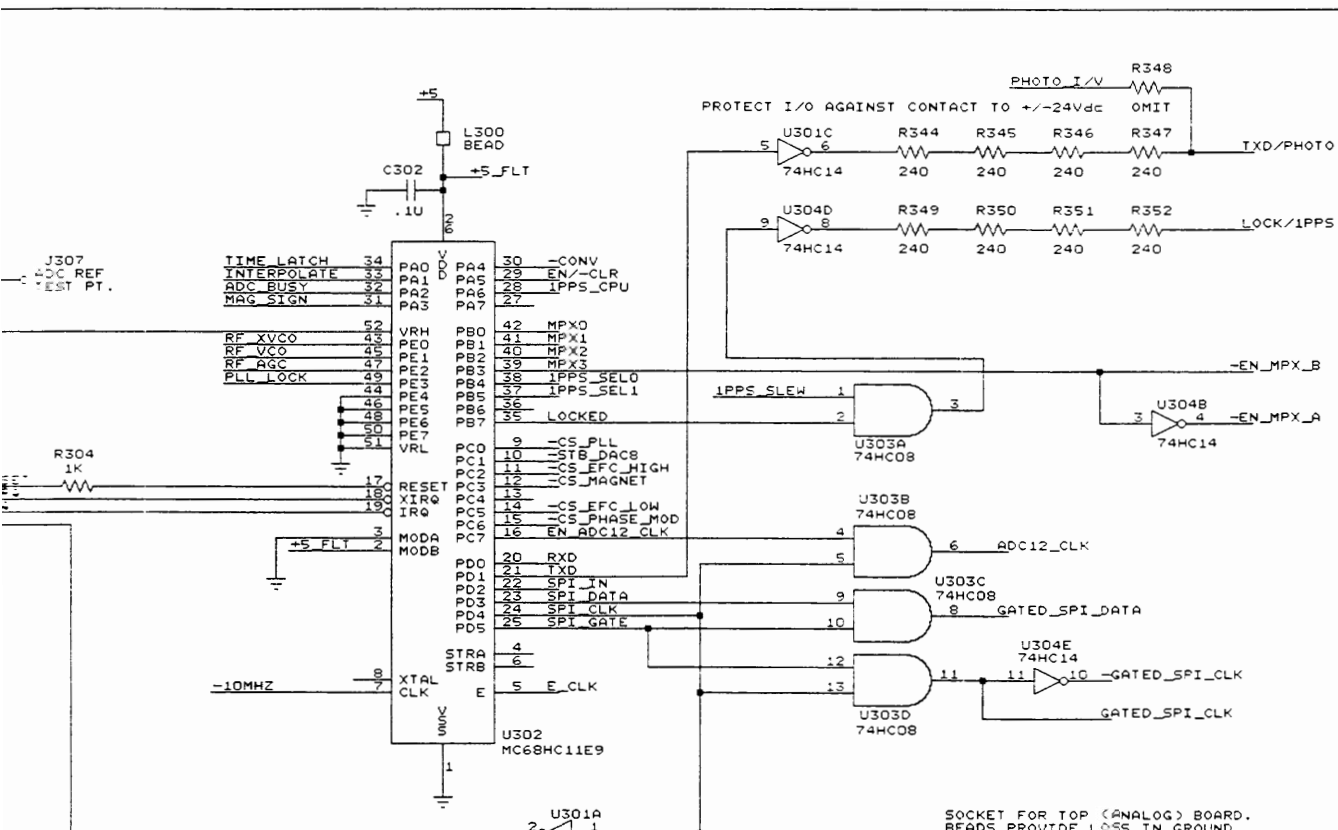

SOCKET FOR TOP (ANALOG) BOARD.
BEADS PROVIDE LOSS IN LARGE
LOOP AROUND THE FOUR LARGE PCBs.

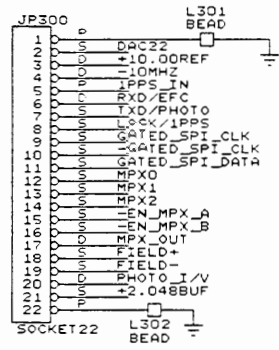

SOCKET FOR BOTTOM (POWER SUPPLY) BOARD

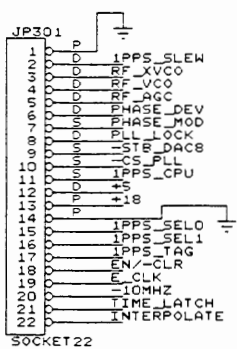

S=SOURCE OF SIGNAL ON THIS PCB
D=DESTINATION OF SIGNAL IS THIS PCB
P=PASS THROUGH OF SIGNAL ON THIS PCB

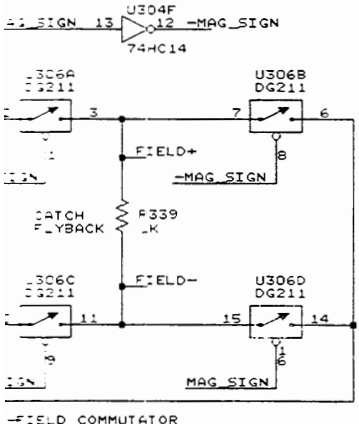

-FIELD COMMUTATOR

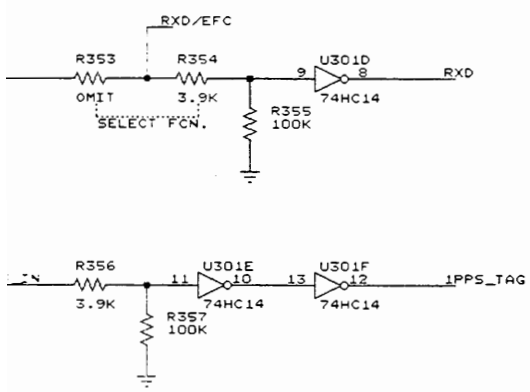

74HC PARTS ON THIS PAGE
HAVE POWER CALLED VCC.

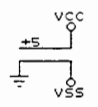

STANFORD RESEARCH SYSTEMS	
Title	MICROCONTROLLER, A/D's and D/A's (SIDE)
Size	Document Number
C	RB_H3
Date:	August 12, 1999 Sheet 3 of 6

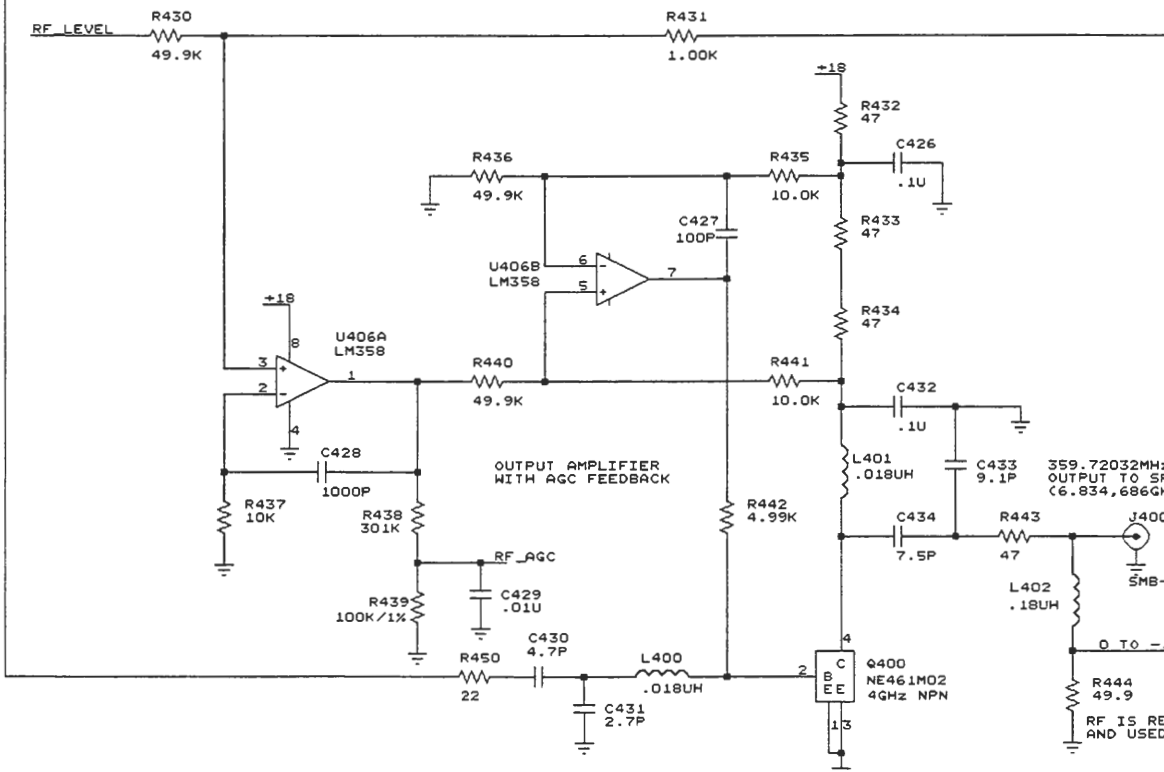
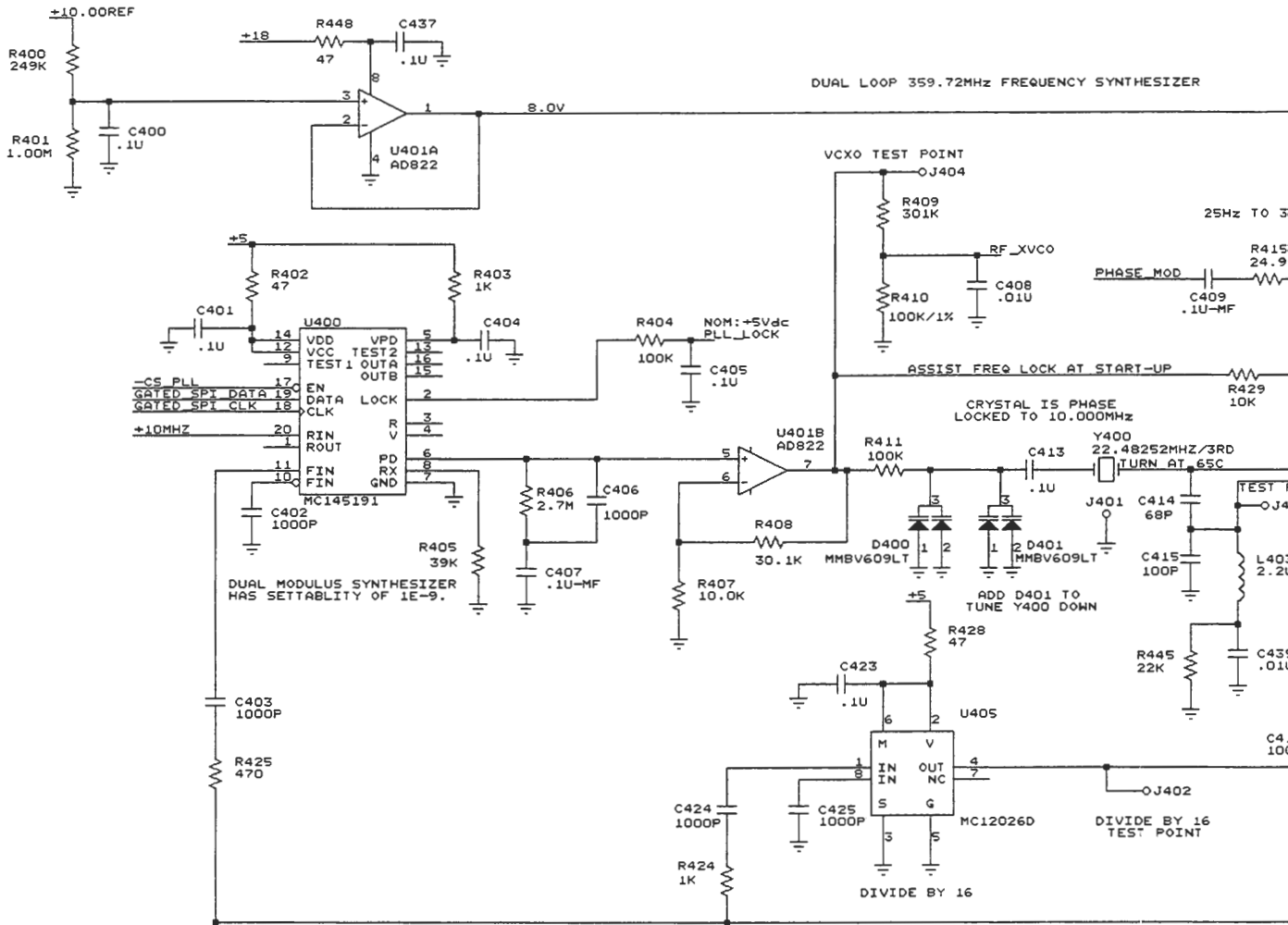

FREQUENCY SYNTHESIZER

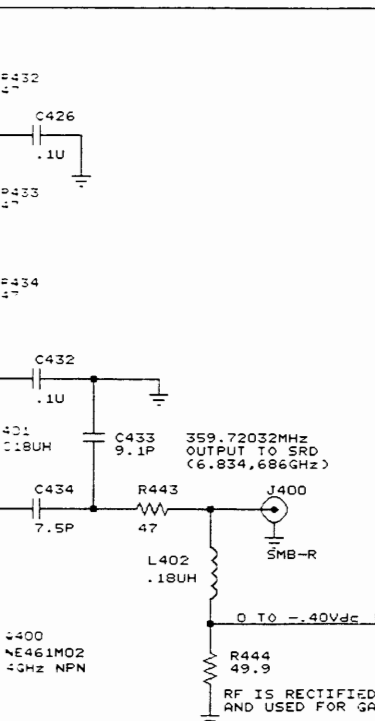
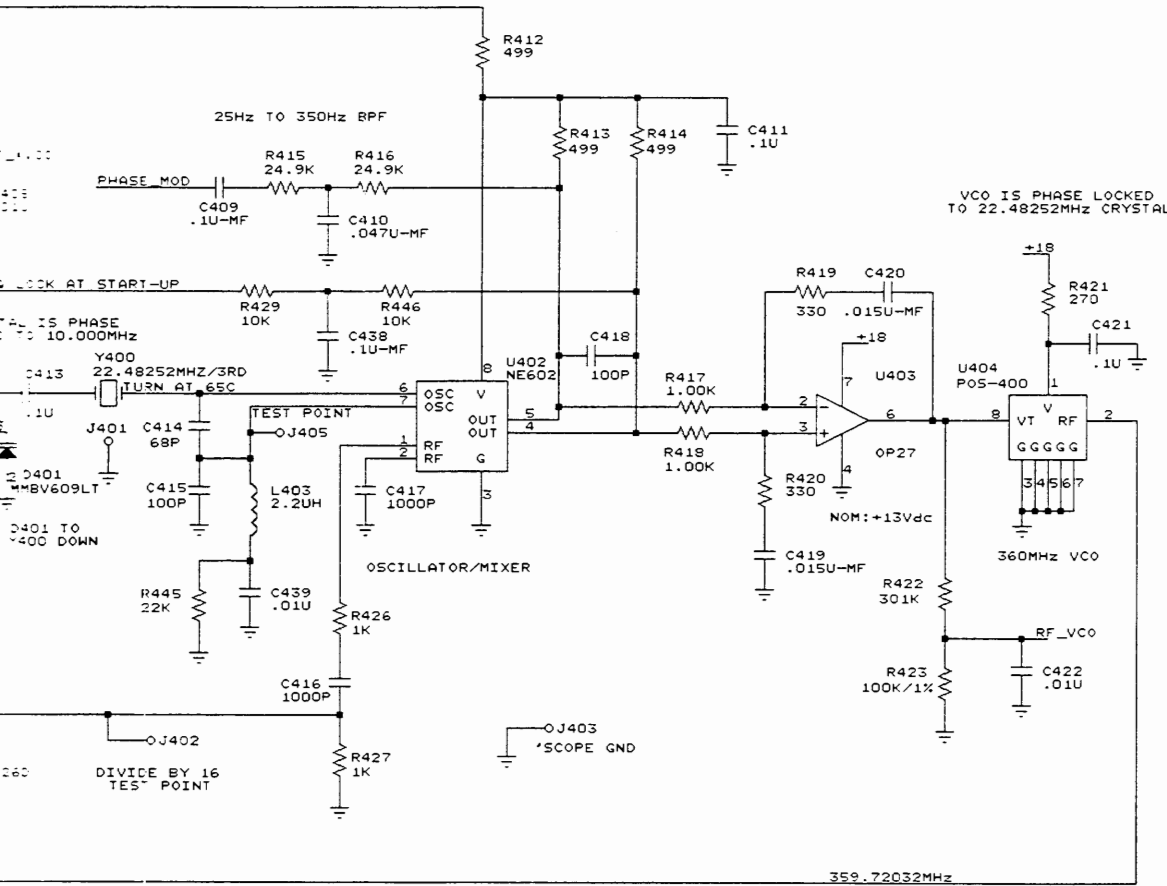

OCTAL 8-BIT DAC PROVIDES ANALOG CONTROL VOLTAGES

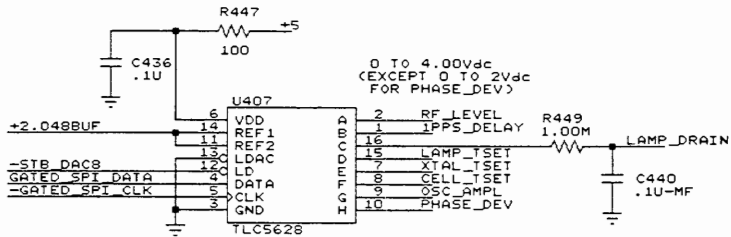

SOCKET TO BOTTOM (P/S) PCB

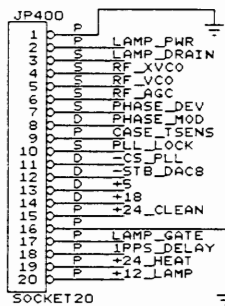

SOCKET TO TOP (ANALOG) PCB

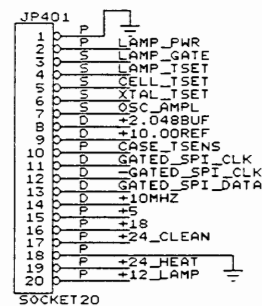

STANFORD RESEARCH SYSTEMS

Title	359.72032MHz FREQUENCY SYNTHESIZER (SIDE)		
Size	Document Number	REV	H
C	RB_H4		H
Date:	August 12, 1999	Sheet	4 of 6

S=SOURCE OF SIGNAL ON THIS PCB
D=DESTINATION OF SIGNAL IS THIS PCB
P=PASS THROUGH OF SIGNAL ON THIS PCB

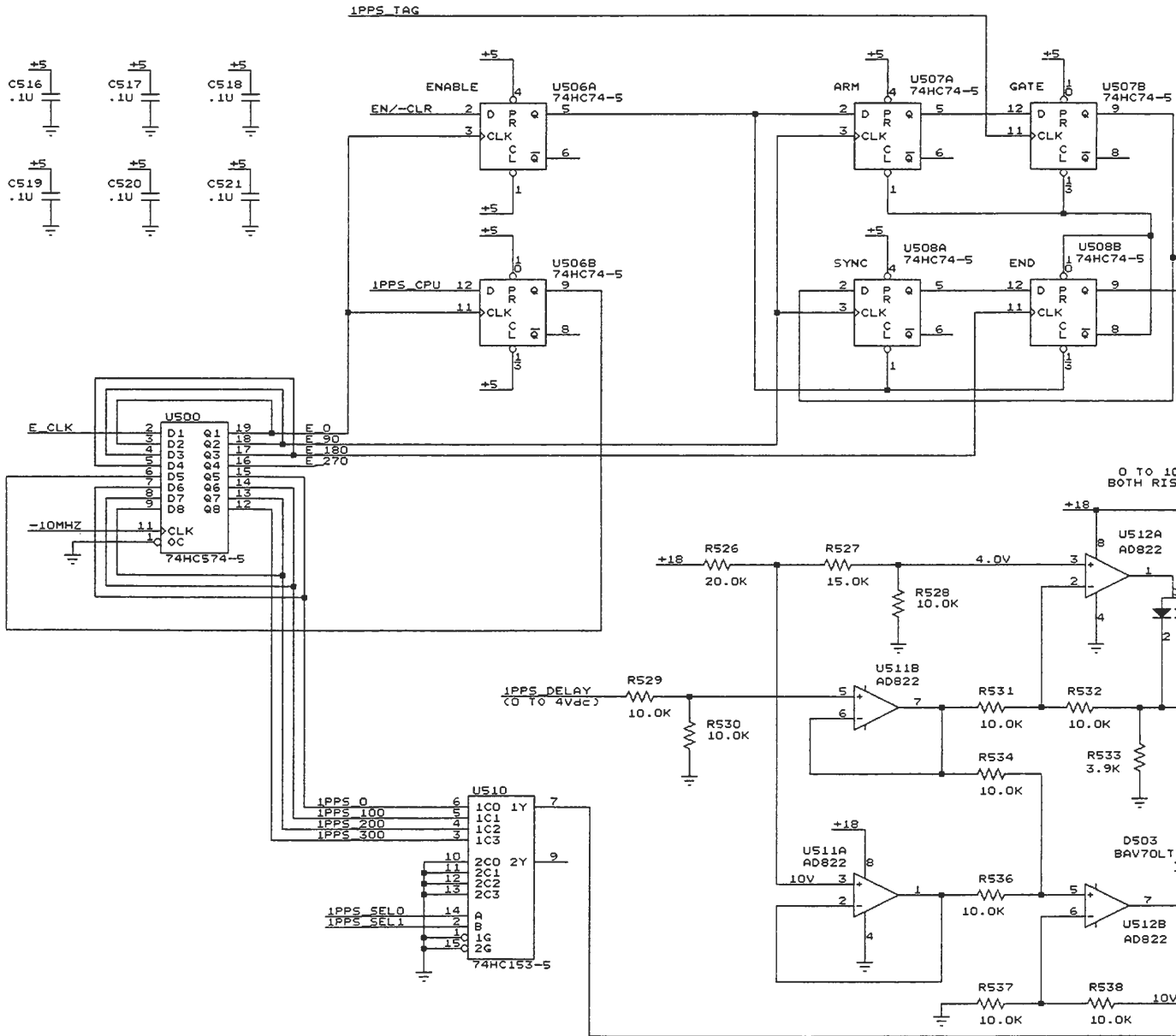
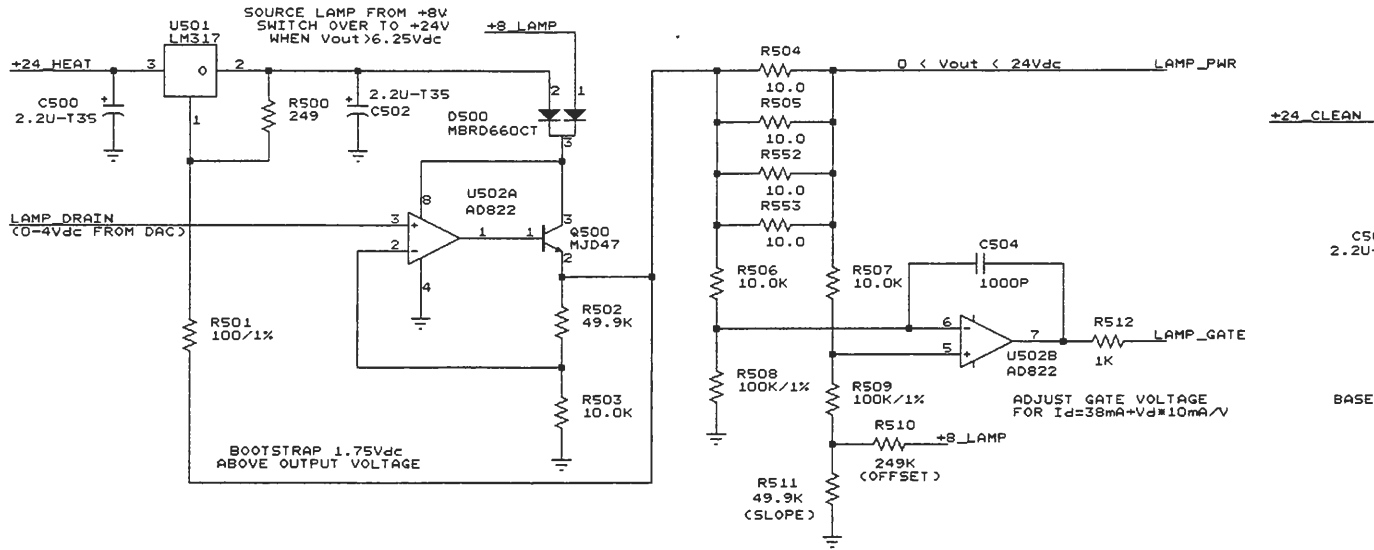

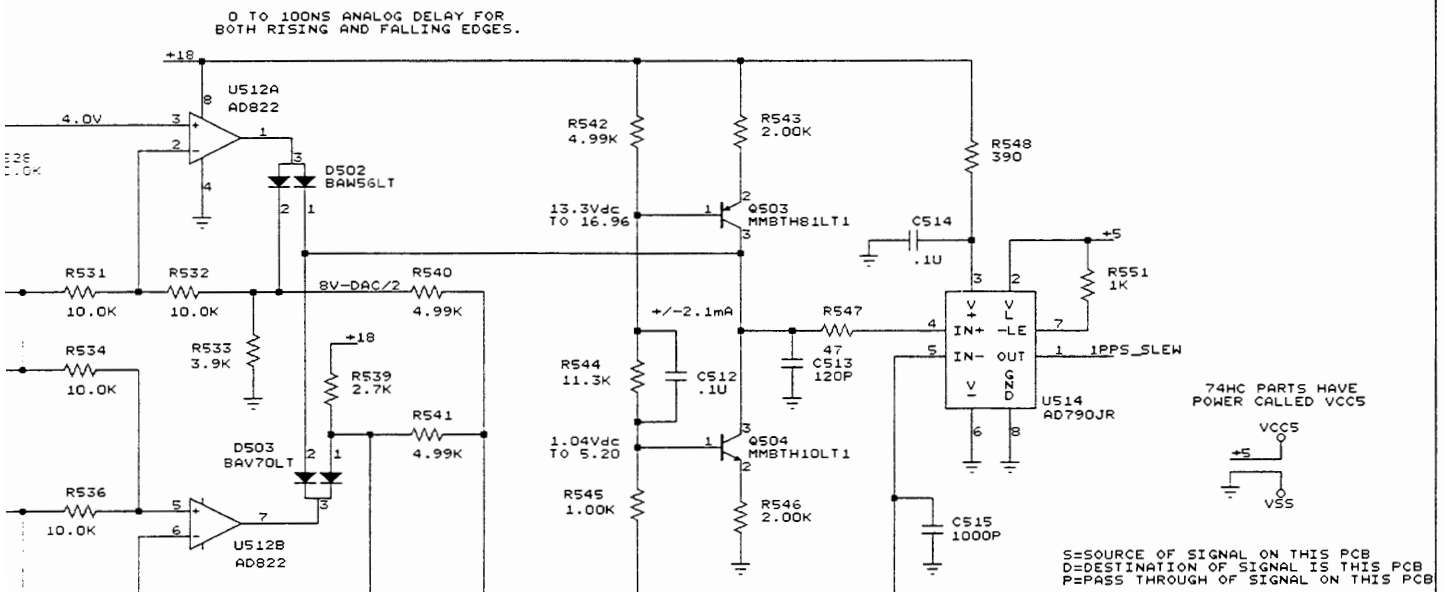
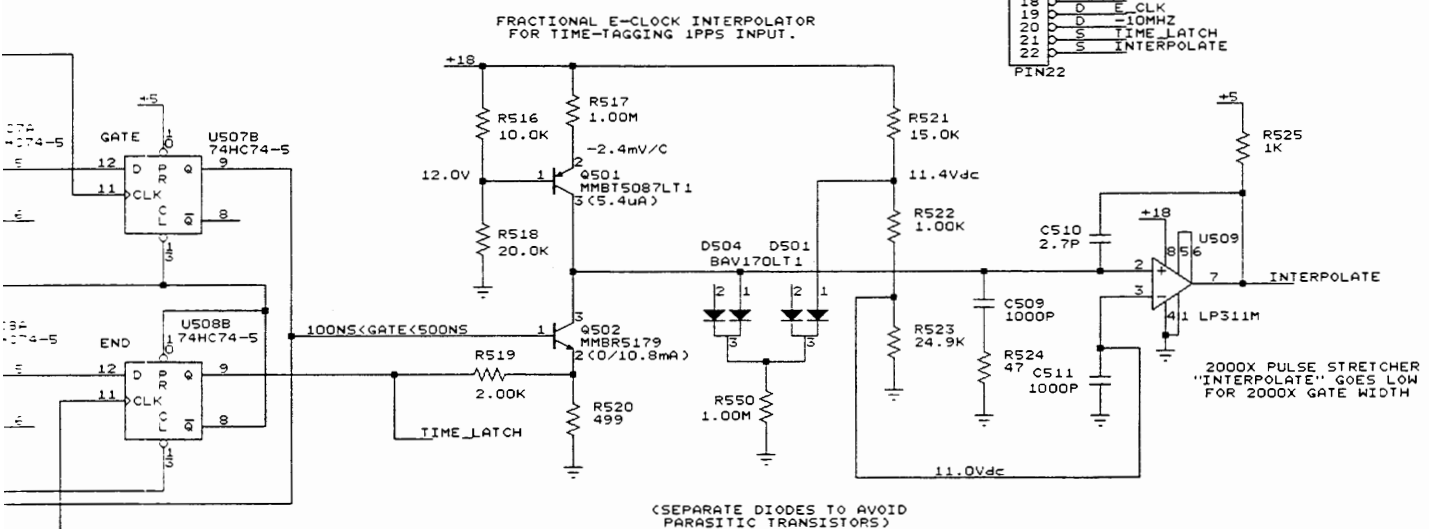
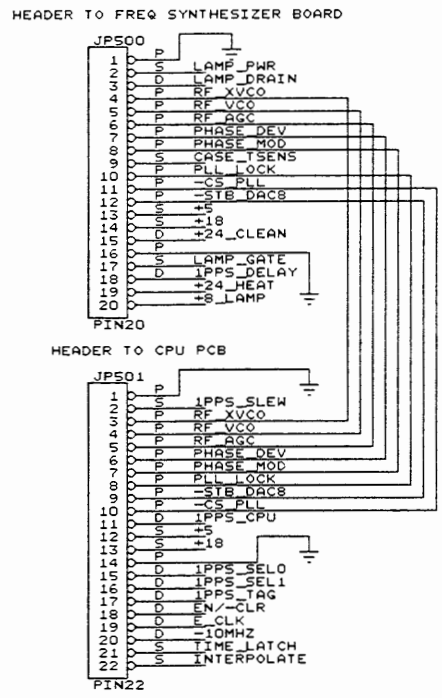
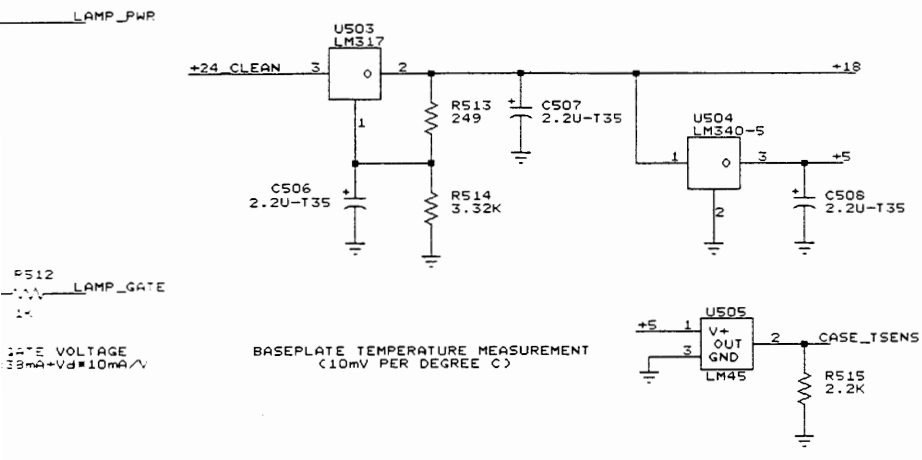

STANFORD RESEARCH SYSTEMS

Title	POWER SUPPLIES AND 1PPS TIMING (BOTTOM)		
Size	Document Number	REV	H
C	RB_H5		
Date:	August 12, 1999	Sheet	5 of 6

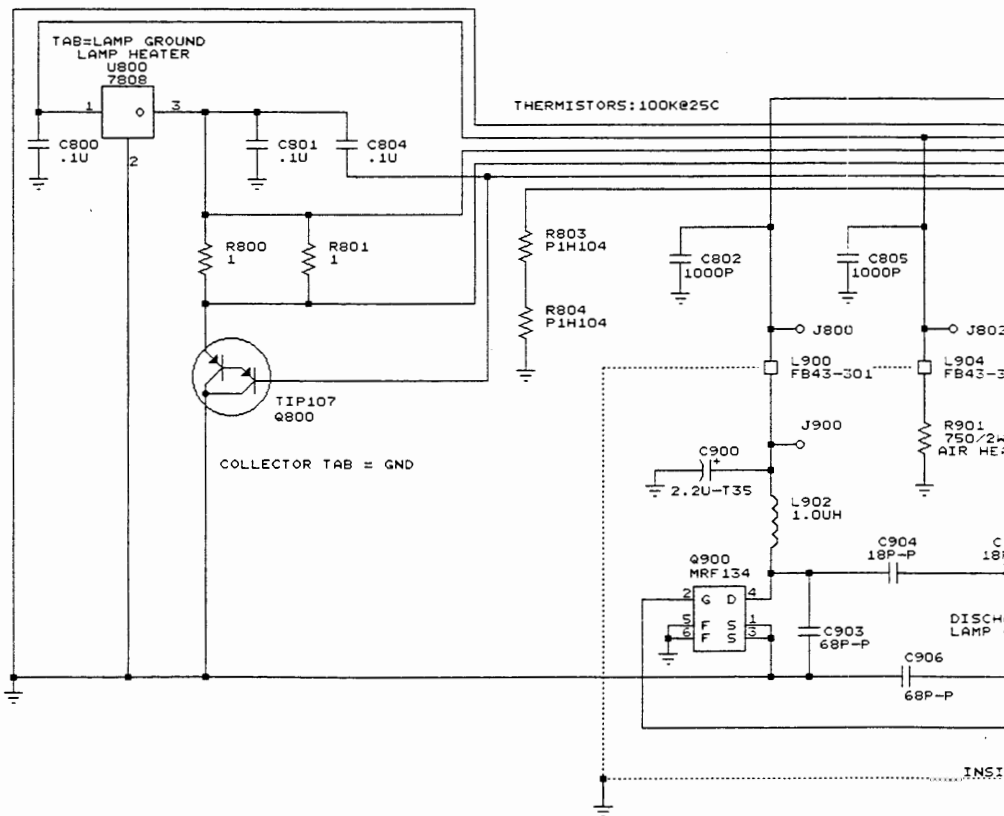
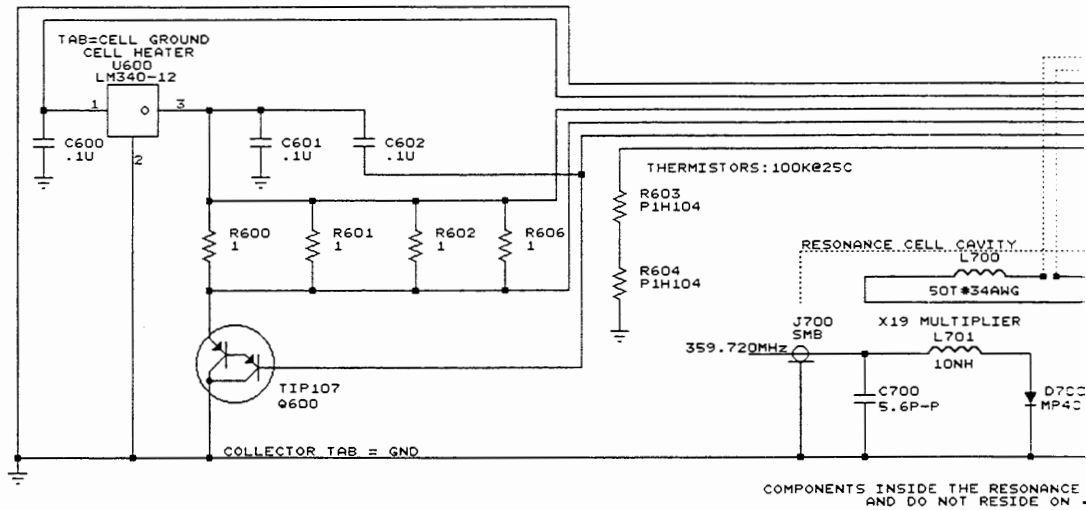

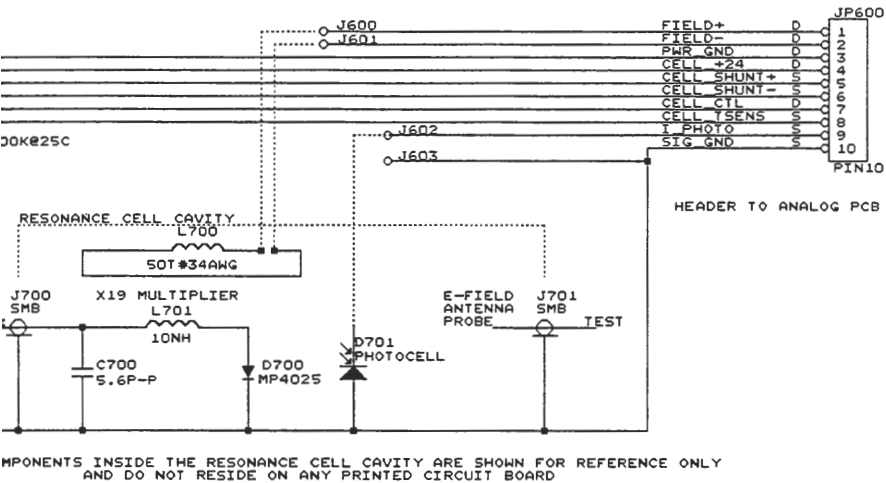

REFERENCE DESIGNATORS:
 600's ARE PART OF CELL HEATER
 700's ARE INSIDE RESONANCE CELL
 800's ARE PART OF LAMP HEATER
 900's ARE PART OF DISCHARGE CIRCUIT
 S=SOURCE OF SIGNAL ON THIS PCB
 D=DESTINATION OF SIGNAL IS THIS PCB
 P=PASS THROUGH OF SIGNAL ON THIS PCB

STANFORD RESEARCH SYSTEMS			
Title RESONANCE CELL AND DISCHARGE LAMP			
Size	Document Number	REV	
C	RB_H6	H	H
Date:	August 12, 1999	Sheet	6 of 6